



A QUICK INTRODUCTION TO SLIDING MODE CONTROL AND ITS APPLICATIONS

| | |
|---|----|
| 1. Sliding Mode Control Principles and applications | 2 |
| 2. A simple description | 3 |
| 3. Design example and simulations | 9 |
| 4. Applications | 14 |
| 4.1 Some applications developed at DIEE | 15 |
| 4.1.1 Overhead cranes | 15 |
| 4.1.2 Marine vehicles | 17 |
| 4.1.3 Electrohydraulic valve actuator | 19 |
| 4.1.4 Combined cycle plants | 21 |



1 Sliding Mode Control Principles and applications

Sliding mode control (SMC) is a nonlinear control technique featuring remarkable properties of accuracy, robustness, and easy tuning and implementation.

SMS systems are designed to drive the system states onto a particular surface in the state space, named sliding surface. Once the sliding surface is reached, sliding mode control keeps the states on the close neighbourhood of the sliding surface. Hence the sliding mode control is a two part controller design. The first part involves the design of a sliding surface so that the sliding motion satisfies design specifications. The second is concerned with the selection of a control law that will make the switching surface attractive to the system state [1].

There are two main advantages of sliding mode control. First is that the dynamic behaviour of the system may be tailored by the particular choice of the sliding function. Secondly, the closed loop response becomes totally insensitive to some particular uncertainties. This principle extends to model parameter uncertainties, disturbance and non-linearity that are bounded.

From a practical point of view SMC allows for controlling nonlinear processes subject to external disturbances and heavy model uncertainties.

The main basic principles of SMC are outlined in the following important references [1]-[3]:

[1] V.I. Utkin, *Variable Structure systems with Sliding Modes*. IEEE Transaction on Automatic Control, 22, 2, 212-222, 1977.

[2] Raymond A. DeCarlo, Stanislaw H. Zak, and Gregory Mathews, "Variable Structure Control of Nonlinear Multivariable Systems: A Tutorial", Proceedings of the IEEE, vol. 76, No. 3, Mar. 1988

[3] J. Y, Hung, W. Gao, and J.C Hung, "Variable Structure Control: A Survey", IEEE Trans. on Industrial Electronics, vol. 40, No. 1, Feb. 1993

The next interesting reference [4] focuses on the problems arising in the practical implementation of this class of techniques.

[4] K.D. Young, V.I. Utkin and Ü. Özgüner, "A control engineer's guide to Sliding Mode Control". *EEE Transactions on Control Systems Technology* 7 (1999) (3), pp. 328-342

The recently published (April 2008) book [B1] offers a very up-to-date overview of the most promising current line of theoretical and applied research in the field.

[B1] *Modern Sliding Mode Control Theory. New Perspectives and Applications*.
G. Bartolini, L. Fridman, A. Pisano, E. Usai (Eds.), Springer Lecture Notes in Control and Information Sciences, Vol. 375.



2. A simple description

Consider the nonlinear SISO system

$$\dot{x} = f(x,t) + g(x,t)u \quad (1)$$

$$y = h(x,t) \quad (2)$$

where y and u denote the scalar output and input variable, and $x \in R^n$ denotes the state vector.

The control aim is to make the output variable y to track a desired profile y_{DES} , that is, it is required that the output error variable $e = y - y_{DES}$ tends to some small vicinity of zero after a transient of acceptable duration.

As mentioned, SMC synthesis entails two phases

PHASE 1 ("SLIDING SURFACE DESIGN")

PHASE 2 ("CONTROL INPUT DESIGN")

The first phase is the definition of a certain scalar function of the system state, says

$$\sigma(x): R^n \rightarrow R$$

Often, the sliding surface depends on the tracking error e_y together with a certain number of its derivatives

$$\sigma = \sigma(e, \dot{e}, \dots, e^{(k)}) \quad (3)$$

The function σ should be selected in such a way that its vanishing, $\sigma = 0$, gives rise to a "stable" differential equation any solution $e_y(t)$ of which will tend to zero eventually.

The most typical choice for the sliding manifold is a linear combination of the following type

$$\sigma = \dot{e} + c_0 e \quad (4)$$

$$\sigma = \ddot{e} + c_1 \dot{e} + c_0 e \quad (5)$$

$$\sigma = e^{(k)} + \sum_{i=0}^{k-1} c_i e^{(i)} \quad (6)$$



The number of derivatives to be included (the “k” coefficient in (6)) should be $k=r-1$, where r is the input output relative degree of (1)-(2).

With properly selected c_i coefficients, if one steers to zero the σ variable, the exponential vanishing of the error and its derivatives is obtained.

If such property holds, then the control task is to provide for the finite time zeroing of σ , “forgetting” any other aspects.

From a geometrical point of view, the equation $\sigma = 0$ defines a surface in the error space, that is called “sliding surface”. The trajectories of the controlled system are forced onto the sliding surface, along which the system behaviour meets the design specifications.

A typical form for the sliding surface is the following, which depends on just a single scalar parameter, p .

$$\sigma = \left(\frac{d}{dt} + p \right)^k e \quad (7)$$

$$k=1 \quad \sigma = \dot{e} + pe \quad (8)$$

$$k=2 \quad \sigma = \ddot{e} + 2p\dot{e} + p^2e \quad (9)$$

The choice of the positive parameter p is almost arbitrary, and define the unique pole of the resulting “reduced dynamics” of the system when in sliding.

The integer parameter k is on the contrary rather critical, it must be equal to $r-1$, with r being the relative degree between y and u .

This means that the relative degree of the σ variable is one.

The successive phase (PHASE 2) is finding a control action that steers the system trajectories onto the sliding manifold, that is, in other words, the control is able to steer the σ variable to zero in finite time.

There are several approaches based on the sliding mode control approach:

- standard (or first-order) sliding mode control
 - high-order sliding mode control
-

Emphasis is devoted to the second order sliding mode approach, and some references to the higher order approaches are also given. Common feature of all sliding mode based techniques is that no precise information about the original system dynamics is requested, the controlled system being treated as a completely uncertain "black box" object.

First order sliding mode control

The control is discontinuous across the manifold $\sigma = 0$.

$$u = -U \operatorname{sgn}(\sigma) \quad (10)$$

that is

$$u = \begin{cases} -U & \sigma > 0 \\ U & \sigma < 0 \end{cases} \quad (11)$$

U is a sufficiently large positive constant.

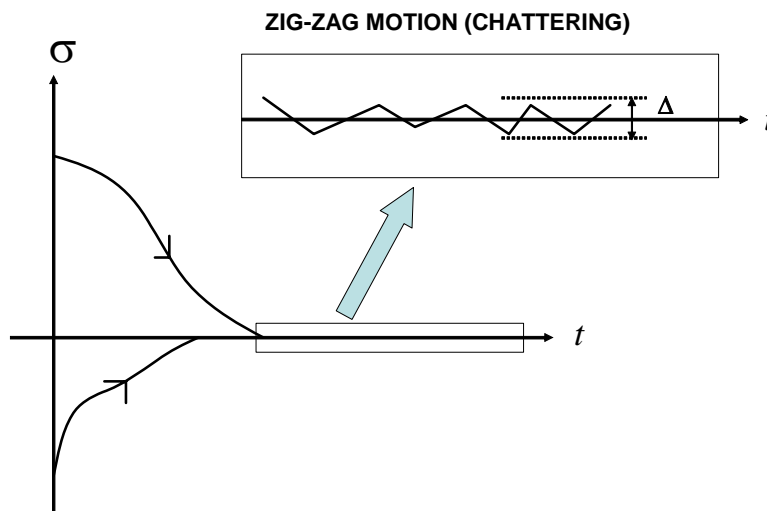

Fig. 1 Typical evolution of the σ variable starting from different initial conditions

In steady state the control variable u will commute at very high (theoretically infinite) frequency between the values $u = U$ and $u = -U$ (see Fig. 2)

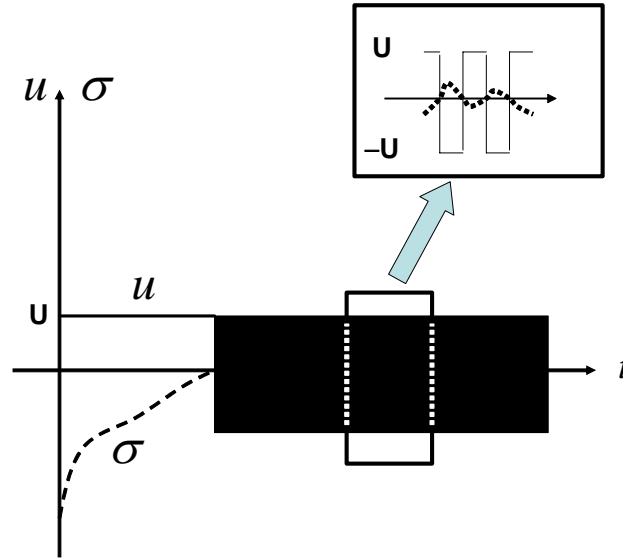

Fig. 2 Typical evolution of the control signal u (the dashed line represents σ)

The discontinuous high frequency switching control (Figure 2) is appropriate in “electrical” applications (where PWM control signals are normally employed) but gives rise to oscillations and many problems in different areas like, e.g., the control of mechanical systems.

In order to solve the above problem (referred to as “**chattering phenomenon**”) approximate (smoothed) implementations of sliding mode control techniques have been suggested where the discontinuous “sign” term is replaced by a continuous smooth approximation. Two examples follow

$$\text{SAT} \quad u = -U \operatorname{sat}(\sigma; \varepsilon) \equiv -U \frac{\sigma}{|\sigma| + \varepsilon} \quad \varepsilon > 0 \quad \varepsilon \approx 0 \quad (12)$$

$$\text{TANH} \quad u = -U \tanh(\sigma/\varepsilon) \quad \varepsilon > 0 \quad \varepsilon \approx 0 \quad (13)$$

Unfortunately this approach is effective only in specific case, the is when hard uncertainties are not present and the control action that counteract them can be set to zero in the sliding mode.

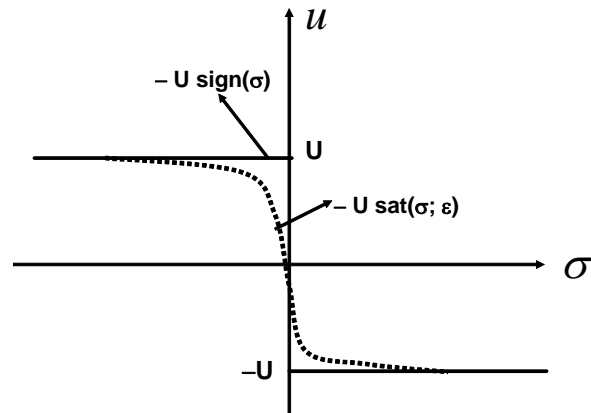

Fig. 3 Smooth approximations of sliding mode control

Second order sliding mode control

Using the above described smooth approximations, some problems are attenuated, at the price of a loss of robustness.

Second order sliding mode control algorithms are a powerful alternative that completely solves the chattering issue without compromising the robustness properties as well.

Some good references about second-order sliding mode control (2-SMC) algorithms are the following:

[5] Arie Levant "Sliding order and sliding accuracy in sliding mode control", *International Journal of Control*, 58(6), 1993, 1247-1263)

[6] G. Bartolini, A. Ferrara, A. Levant, E. Usai "On second order sliding mode controller" in *Variable structure systems, sliding mode and nonlinear control*, Springer Lecture Notes in Control and Information Sciences, Volume 247/1999.

One popular (2-SMC) algorithm is the so called

"SuperTwisting" Algorithm

$$u = -\lambda\sqrt{|\sigma|} \operatorname{sgn}(\sigma) + w \quad (14)$$

$$\dot{w} = -W \operatorname{sgn}(\sigma) \quad (15)$$

A suitable way for tuning its parameters is the following pair of relationships

$$\lambda = \sqrt{U} \quad W = 1.1U \quad (16)$$

where U is a positive constant to be taken sufficiently large. In practice, one has to progressively increase U until good performances are seen in the closed loop system. This kind of single-parameter “trial and error” tuning is particularly suited in practical implementation.

The super-twisting algorithm can be seen as a nonlinear version of the classical PI controller. This analogy is clearer by referring to the next Figure 4

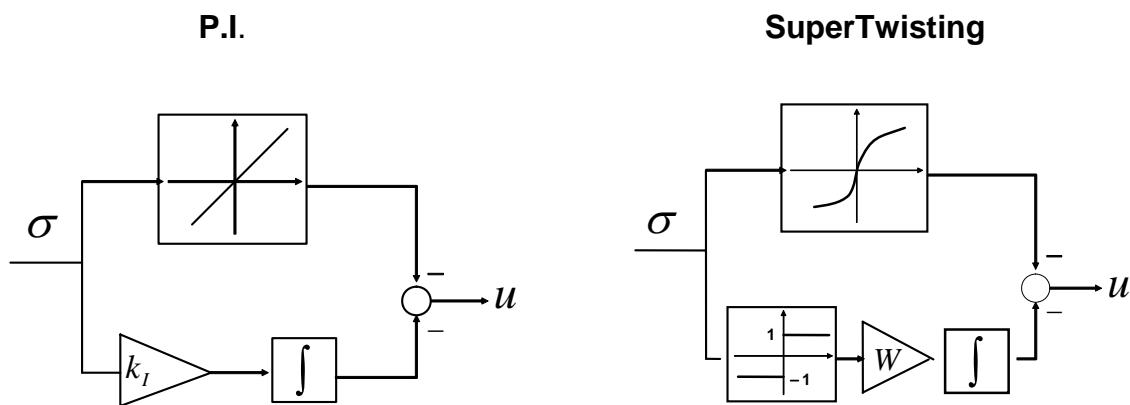

Fig 4. Bloch scheme of PI (left) and Super-Twisting (right) controllers

Second order SMC solves the chattering issue since the control law is now a **continuous** function of time. The improvement due to the use of 2-SMC versus standard SMC are highlighted by means of the next design example.

In the presence of unmodelled dynamics some residual chattering is present, but there exist some design approaches to second-order sliding modes that allow for limit such an undesired phenomenon.



3. Design example and simulations

To investigate the main aspects of SMC design, let us consider a simple yet challenging motion control problem, namely the position control for an **uncertain** mass-spring-damper subject to an **uncertain** time varying disturbance $d(t)$.

$$M\ddot{x} + B\dot{x} + Kx = F + d(t) \quad (17)$$

Since the structure of the disturbance $d(t)$ is unknown, no linear controller can completely reject it unlike in very special cases (e.g., $d(t)=\text{cost.}$).

Let us define the output as $y = x$.

The desired position profile is

$$y_{DES}=5 \sin(2t). \quad (18)$$

Define the tracking error as

$$e = y - y_{DES} \quad (19)$$

PHASE 1. Sliding surface design

The relative degree between the output $y(t)$ and the input $F(t)$ is **$r=2$** .

Thus, according to (8) (in this case $k=r-1=1$) define the sliding surface σ as follows

$$\sigma = \dot{e} + pe = \dot{y} - \dot{y}_{DES} + p \cdot (y - y_{DES}) \quad (20)$$

Let $p = 1$

$$\sigma = \dot{e} + e \quad (21)$$

PHASE 2. Control input design

Let us apply the three different suggested alternatives

- First order SMC

$$F = -F^* \text{sign}(\sigma) \quad (22)$$

- First order “smoothed SMC

$$F = -F^* \text{sat}(\sigma; \varepsilon) \quad (23)$$

- Supertwisting 2-SMC

$$F = F_1 + F_2 \quad (24)$$

$$F_1 = -\sqrt{F^*} \sqrt{|\sigma|} \text{sgn}(\sigma) \quad (25)$$

$$\dot{F}_2 = -1.1F^* \text{sgn}(\sigma) \quad (26)$$

Parameter values

$$M=2\text{kg}$$

$$B=5\text{N/ms}^2$$

$$K=2 \text{ N/m}$$

External disturbance

$$d(t)=2 + 2 \sin (3t) + \sin (5t) \quad (27)$$

First order SMC

$$F = -F^* \text{sign}(\sigma)$$

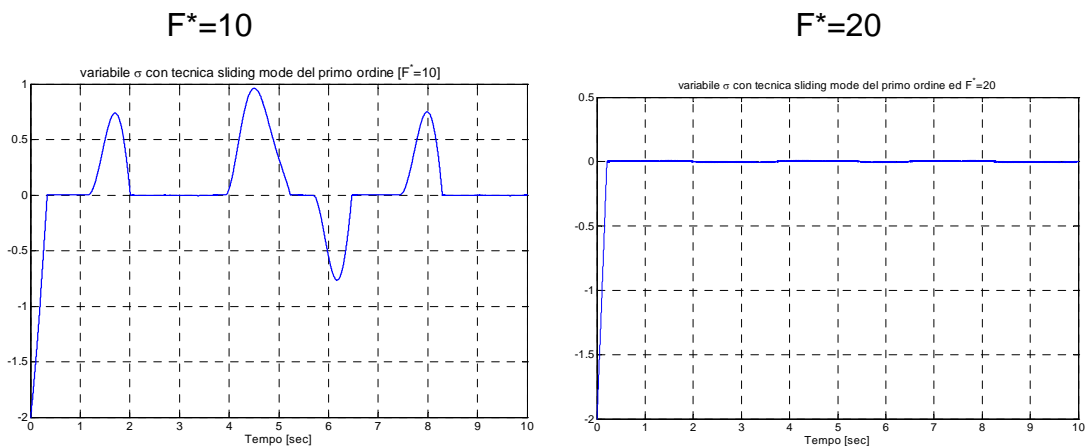

Fig. 5 The sliding variable σ with first order SMC Left: $F^*=10$. Right $F^*=20$.

In figure 5-left the control authority (i.e. the F^* parameter) is too low, and, as a result, the sliding variable σ sometimes escapes from zero. In figure 5-right it has been increased enough to achieve good precision in keeping σ to zero.

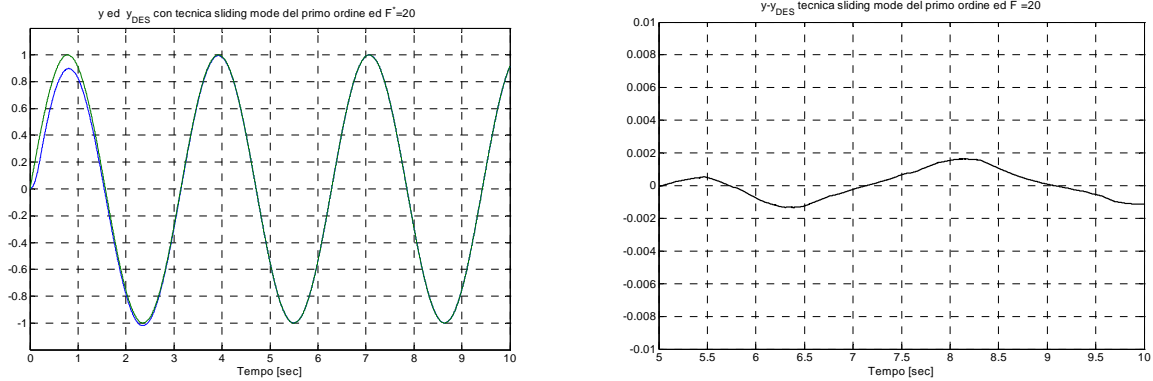

Fig. 6 First order SMC with $F^*=20$. Left plot: y and y_{DES} . Right plot: $e := y - y_{DES}$

The control input is depicted in the next plot. It is apparent the discontinuous high frequency nature of the control input. This behaviour is unacceptable for a physical signal like a mechanical force.

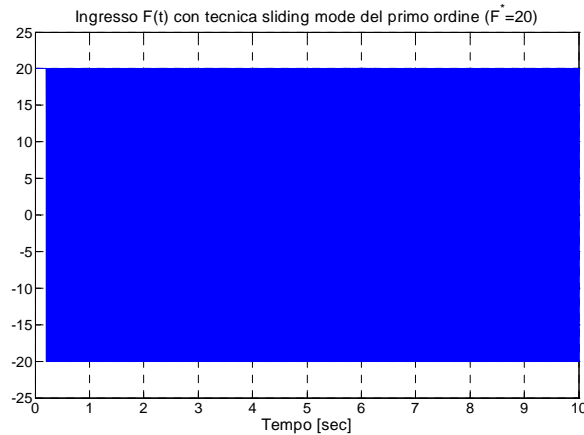

Fig. 7 First order SMC with $F^*=20$. The control input $F(t)$

Smoothed first order SMC

$$F = -F^* \text{sat}(\sigma; \varepsilon) \quad (28)$$

The smoothed implementation (28) is tested to remove the discontinuity from the control law.

$F^* = 20$ ed $\varepsilon=0.001$

Control input

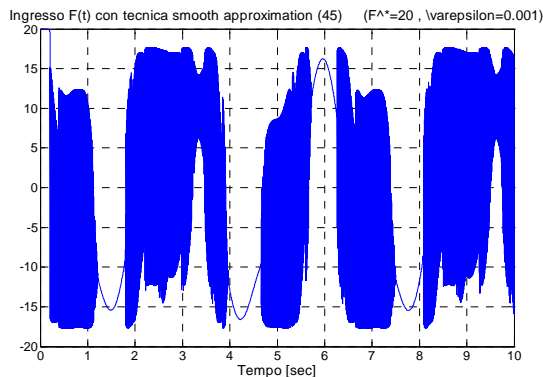

Tracking error

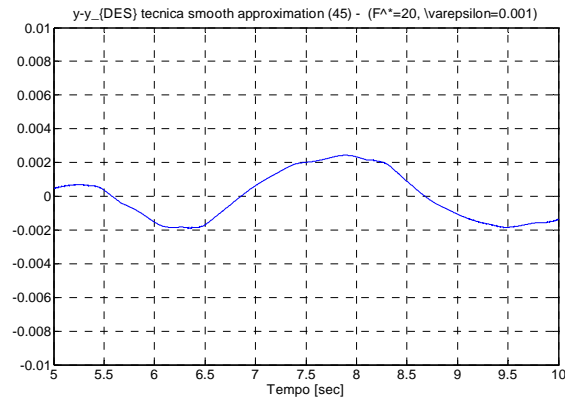

$F^* = 20$ ed $\varepsilon=0.01$

Control input

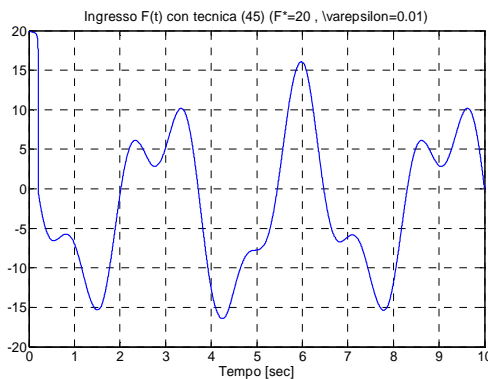

Tracking error

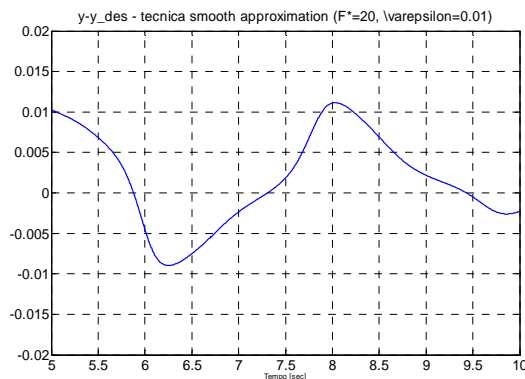

The above two tests show that with small ε ($\varepsilon=0.001$) the smoothing effect on the control input is limited, but the control accuracy is retained, while with larger ε ($\varepsilon=0.01$) the smoothing effect is remarkable but there is a loss of accuracy. Therefore a good compromise must be found.

This technique proved to be very effective and is of widespread use in many SMC implementation.

“Super-twisting” 2-SMC

The second order sliding mode control approach solves the chattering issue improving the control accuracy at the same time.

$$F = F_1 + F_2 \quad (29)$$

$$F_1 = -\sqrt{F^*} \sqrt{|\sigma|} \operatorname{sgn}(\sigma) \quad (30)$$

$$\dot{F}_2 = -1.1F^* \operatorname{sgn}(\sigma) \quad (31)$$

The tuning parameter is set to $F^*=50$

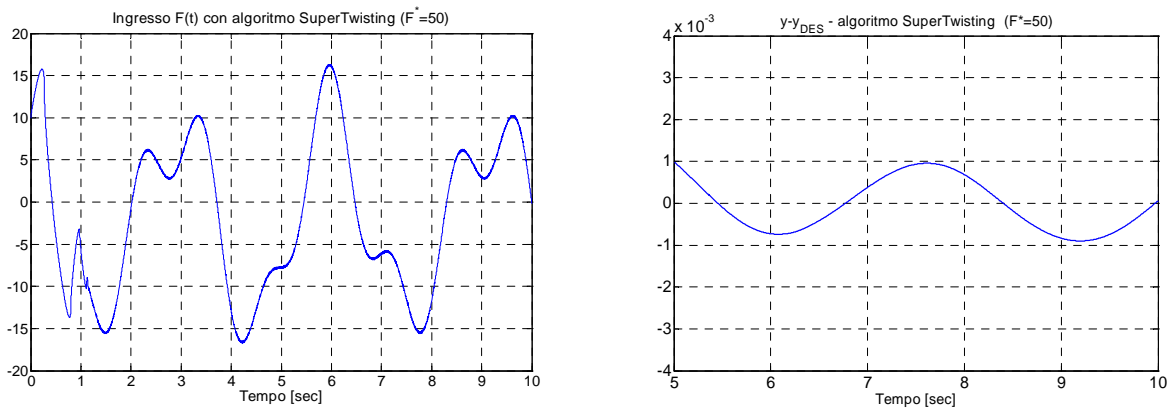

Fig. 8 SuperTwisting with $F^*=50$.Left: the control input. Right: the tracking error.

It can be noted the high accuracy and simplicity of implementation of this class of techniques that, on the basis of practically no information about the plant dynamics, allows a very precise control.



4. Applications

Sliding mode control has found numerous successful applications.

Some applications relevant to different areas are reported.

One of the first successful applications was found in the broad area of power electronics and electrical drives. Here "standard" (i.e., first order) SMC exploits at best his features since "on-off" (high frequency switching) control signals are the standard operating mode in electrical power drives supplied by means of PWM converters.

The following reference offer a clear, although not very up-to date, outline of the subject.

[7] V.I. Utkin "Sliding mode control design principles and applications to electric drives", IEEE Transactions on Industrial Electronics, 40, 1, 23.36, 1993.

A more recent publication on DC motor control via second order sliding modes, including extensive experimental results:

[7a] Damiano A., Gatto G.L., Marongiu I., PISANO A. "Second-order sliding-mode control of DC drives" IEEE Trans. on Industrial Electronics, vol. 51, n. 2, pp. 364-373, 2004.

A more recent and very interesting application to power systems control can be found in

[8] A.G. Loukianov, J.M. Cañedo, V.I. Utkin, J. Cabrera-Vázquez "Discontinuous Controller for Power Systems: Sliding-Mode Block Control Approach", IEEE Transactions on Industrial Electronics, 51, 2, 340-353, 2004.

Examples of application to process control problems, some of which [9,10] seem closely related to Bosio's research interests can be found in

[9] Y.B. Shtessel, ME Jackson "Sliding mode thermal control system for space station furnace facility", IEEE transactions on control systems technology, 1998, vol. 6, n 5, pp. 612-622, 1998.

[10] S. K. Spurgeon, C. Edwards "Sliding Mode Output Tracking With Application To A Multivariable High Temperature Furnace Problem", International Journal of Robust and Nonlinear Control, 7, 4, 337-351, 1998.

[11] G. Herrmann, S. K. Spurgeon, C. Edwards "A model-based sliding mode control methodology applied to the HDA-plant", Journal of Process Control 13 (2003) 129-138



[12] Chyi-Tsong Chen *, Shih-Tien Peng "A sliding mode control scheme for non-minimum phase non-linear uncertain input-delay chemical processes", Journal of Process Control 16 (2006) 37–51

An overview of applications of second order sliding mode control to several types of mechanical systems (including cranes, robot manipulators, train pantographs, and more) can be found in

[13] Bartolini G., Pisano A., Punta E., Usai E. "A survey of applications of second-order sliding mode control to mechanical systems" International Journal of Control, vol. 76, n. 9/10, pp. 875-892, 2003.

4.1 Some applications developed at DIEE

4.1.1 Overhead cranes

The real time control of an overhead crane prototype was addressed using both linear and sliding mode control techniques.

The main references for the above activities are

[14] Bartolini G., PISANO A., Usai E. "Output-feedback control of container cranes: a comparative analysis", Asian Journal of Control, vol. 5, n. 4, pp. 578-593, 2003.

[15] Bartolini G., PISANO A., Usai E. "Second Order Sliding Mode Control for Container Cranes" Automatica, vol. 38, pp. 1783-1790, 2002.

A picture of the experimental prototype follows

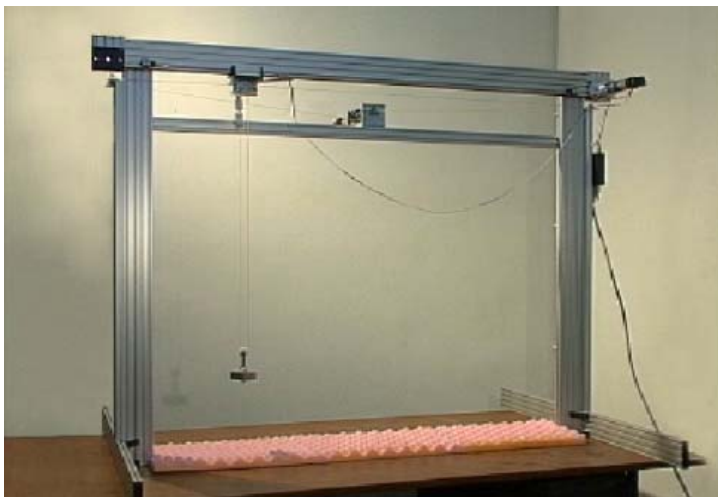

The architecture of the PC based experimental setup is

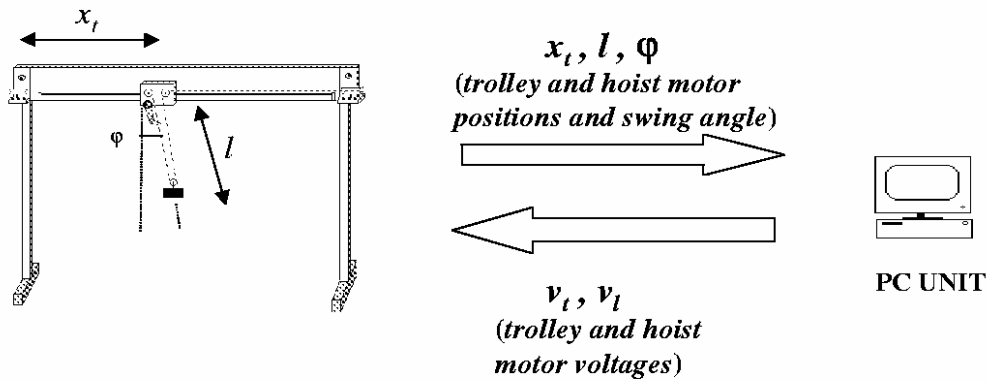

Dynamics of motor drives is explicitly included in the model used for stability analysis. A prescribed parabolic path for the suspended load was established, and the controller was designed to provide for transferring the load along such prescribed path, avoiding the generation of oscillations, and actively damping the oscillations externally generated, e.g., by the wind.

Next plot shows experimental results with a comparison between a linear PI and the second order sliding mode controller.

LINEAR

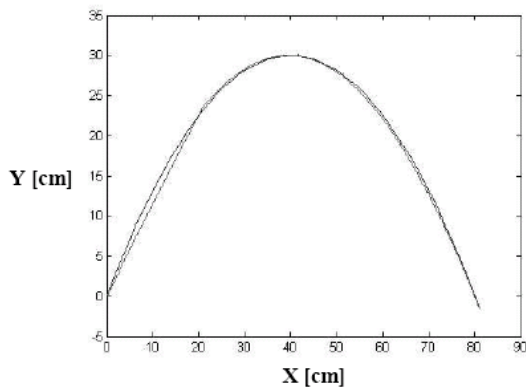

SLIDING MODE

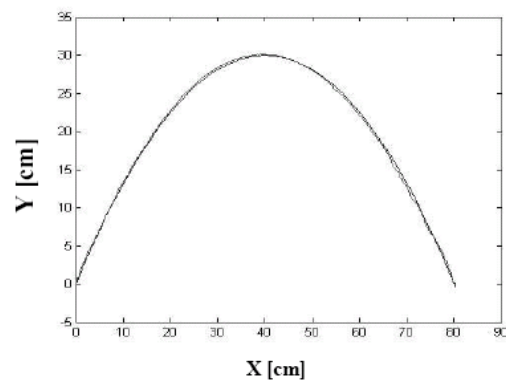



UNIVERSITA' DEGLI STUDI DI CAGLIARI

**DIPARTIMENTO DI INGEGNERIA
ELETTRICA ED ELETTRONICA**

Piazza d'Armi - 09123 CAGLIARI (I)
Tel. +39 070 675 5889 - Fax +39 070 675 5900
<http://www.diee.unica.it>

4.1.2 Marine vehicles

The motion control for jet propelled marine vehicles has been addressed by first and second order sliding mode control methodologies.

The main references for the above activities are

[16] Bartolini G., Orani N. PISANO A., Punta E., Usai E. "A combined first/second order sliding-mode technique in the control of a jet propelled vehicle", International Journal of Robust and Nonlinear Control. Vol. 18, n. 4/5, pp. 570-585, 2007.

[17] PISANO A. Usai E. "Output-feedback control of an underwater vehicle prototype by higher-order sliding modes", Automatica, vol. 40, n. 3, pp. 1525-1530, 2004.

Next picture shows the jet-propelled surface vessel prototype that was built and operated at DIEE.



The bottom view of the vessel, showing the location and orientation of the jet nozzle, follows.

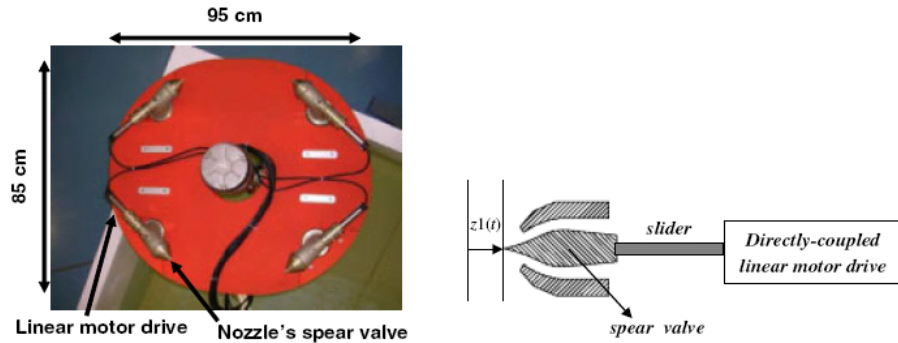

Nect plots show some of the obtained experimental results.

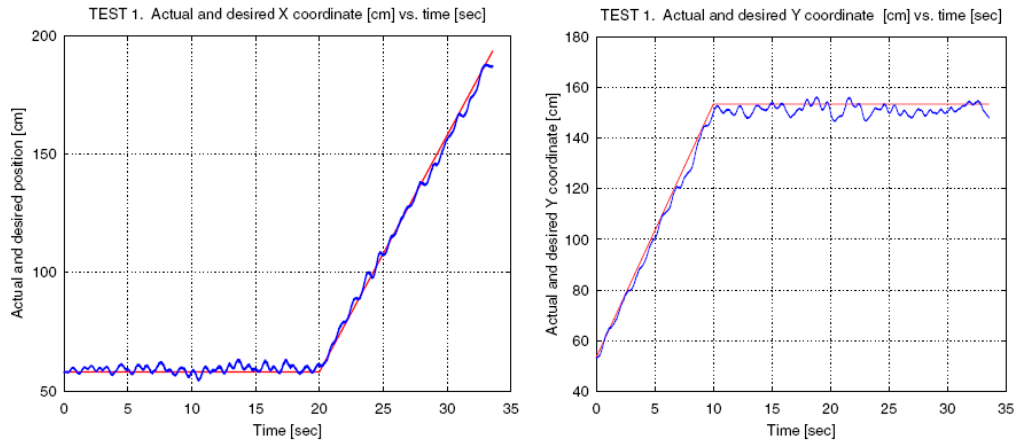

Figure 7. TEST 1. Left: the actual and desired X coordinates vs time. Right: the actual and desired Y coordinates vs time.

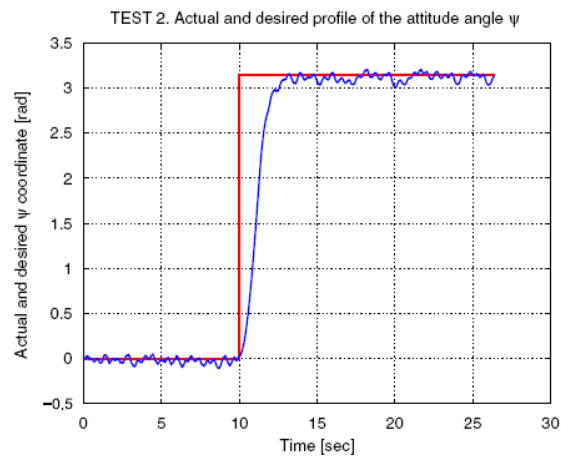

Figure 9. TEST 2. The actual and desired ψ coordinates vs time.

4.1.3 Electrohydraulic valve actuator

The control low two-stage electro-hydraulic valves has been carried out in collaboration with Ansaldo Energia (www.ansaldoenergia.com), one of the leading supplier of components and services for power generation plants. Some of the developed control schemes based on second and higher order sliding mode control have been recently patented in December 2007:

NATIONAL
 PATENT

DECEMBER 2007

“DISPOSITIVO REGOLATORE DI UN ATTUATORE IDRAULICO PER UN ORGANO DI REGOLAZIONE DI UNA TURBINA” (REGULATOR DEVICE FOR AN HYDRAULIC ACTUATOR FOR TURBINES)

Inventors:

A. Pisano and G. Bartolini (DIEE-Univ. of Cagliari)..F. Lombardi ed I. Torre (Ansaldo Energia).

The block scheme of a “double stage” electrohydraulic actuator is reported as follows

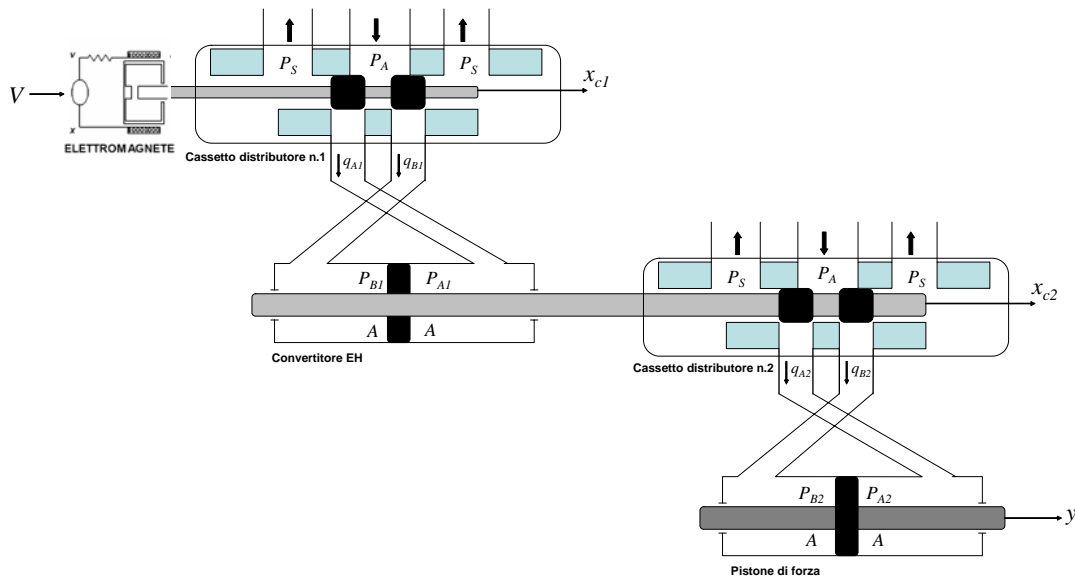

This rather unconventional “double stage” structure is well suited for applications demanding high forces to deliver to the load.

The high relative degree, and the presence of severe and uncertain nonlinearities and disturbances, make the control design for this class of devices an extremely challenging problem. Multiple loop (cascade) and pure output feedback sliding mode control schemes have been developed and tested. A picture of a position regulation test follows.



UNIVERSITA' DEGLI STUDI DI CAGLIARI

**DIPARTIMENTO DI INGEGNERIA
ELETTRICA ED ELETTRONICA**

Piazza d'Armi - 09123 CAGLIARI (I)
Tel. +39 070 675 5889 - Fax +39 070 675 5900
<http://www.diee.unica.it>

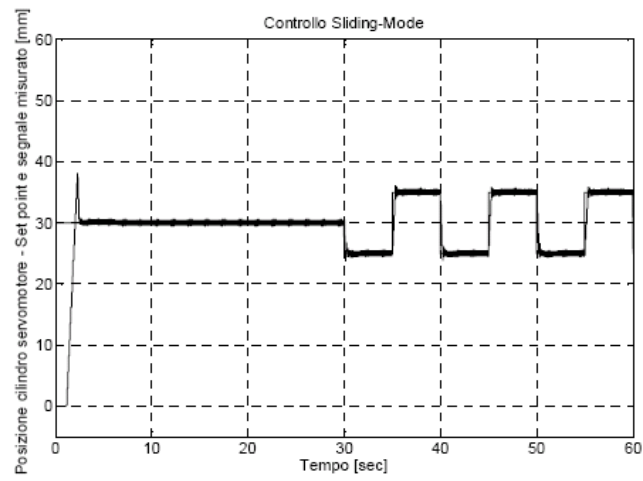

4.1.4 Combined cycle plants

Another applied research activity conducted in collaboration with Ansaldo Energia has dealt with the “redesign” of the fuel and IGV controllers for a 400 MW combined cycle power plant.

An extremely detailed model of all processes and components involved was provided by Ansaldo. The provided simulation model was thoroughly validated by Ansaldo by means of extensive real measurement campaigns taken on the plant located in northern Italy.

On the basis of the given model, a second order sliding mode control system was developed and tested by simulations.

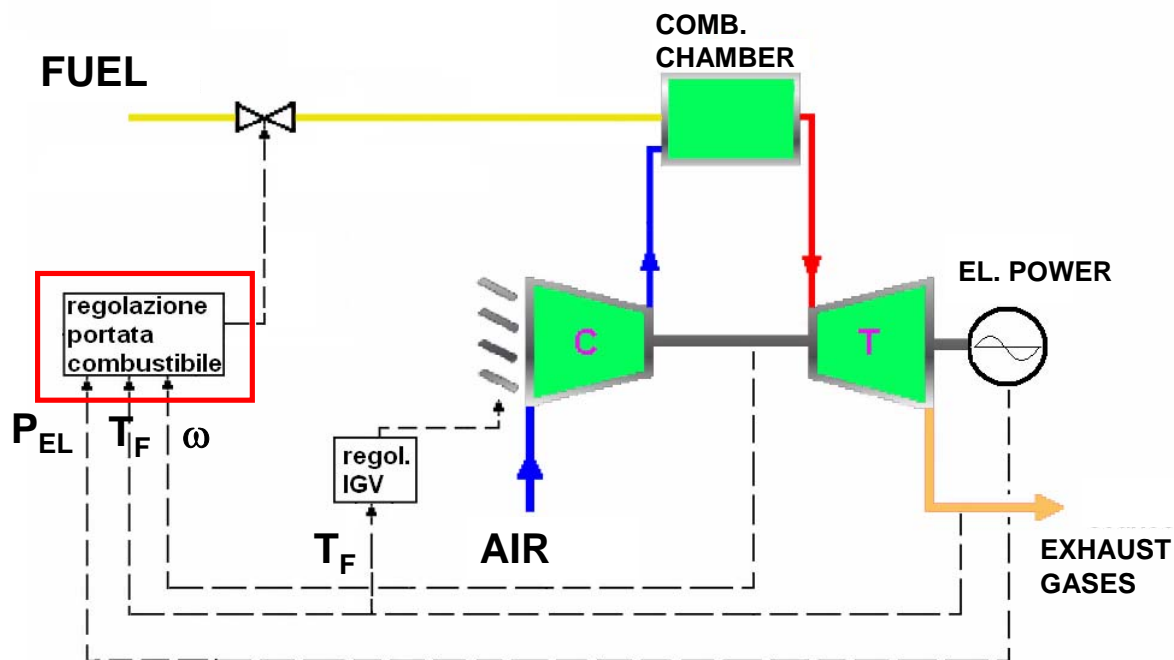

Roughly speaking, the control problem here is to regulate the delivered electrical power while keeping, at the same time, the temperature of the exhaust gases within an acceptable range. The linear controller, which is currently running in the real plant, was compared to the proposed sliding mode controller. A faster power control capability was achieved. The next plots show the effect of changing the power demand. The linear controller (on the left) shows a slower response time as compared to the sliding mode controller. The temperature remained within the acceptable limit (an override controller is responsible for that). The tuning of the sliding mode control scheme was extremely fast and simple.

The activities are still ongoing, the details are covered by privacy agreements, and no publications or patents have been still carried out.



LINEAR CONTROL

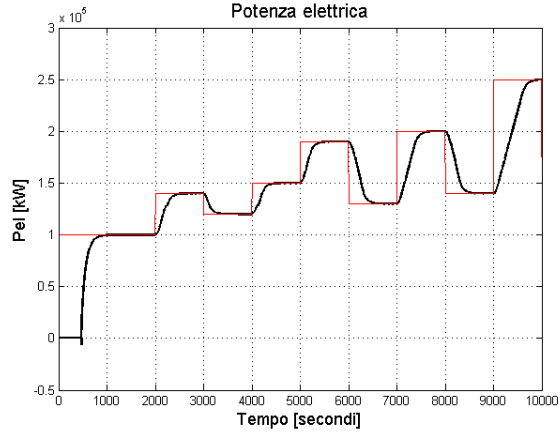

SLIDING MODE CONTROL

