

Other  $\nabla 6.3$

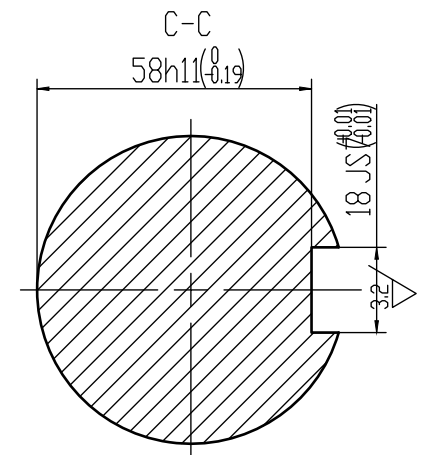

A-A

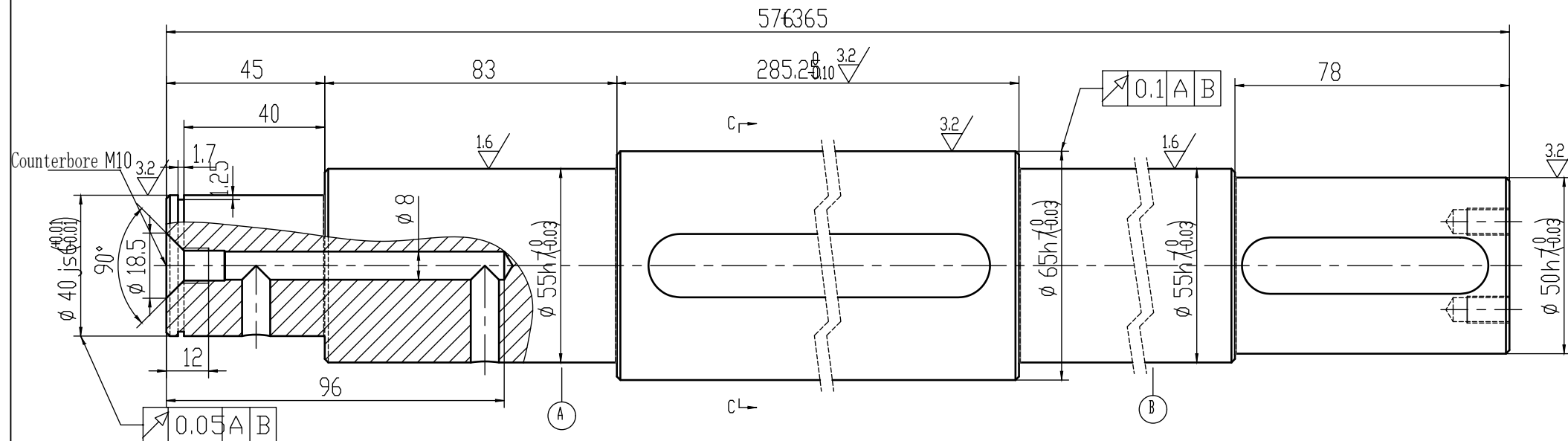
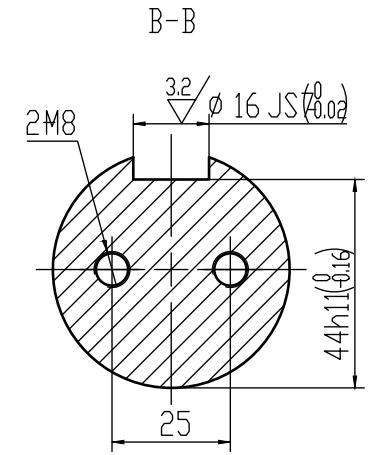
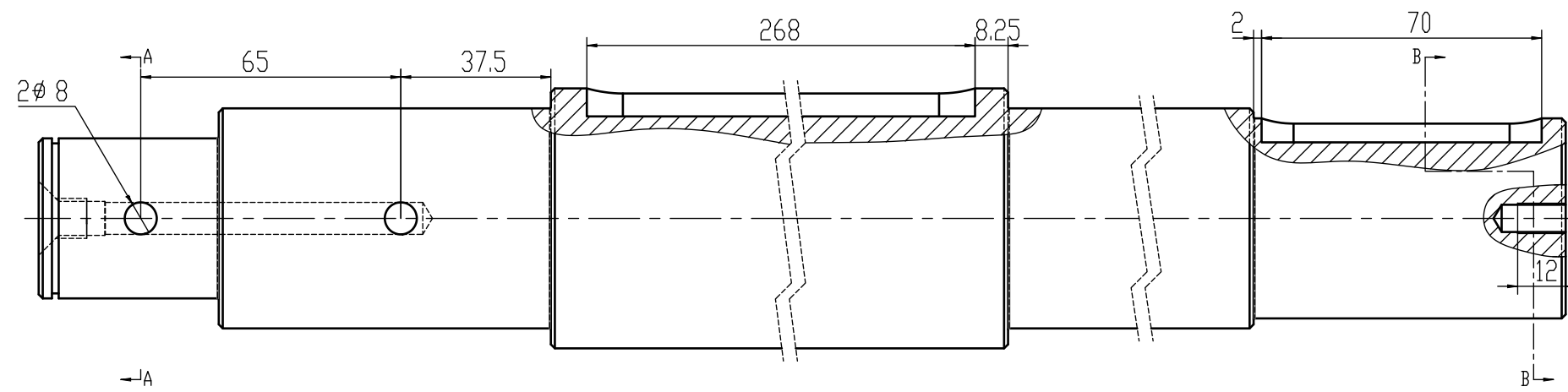
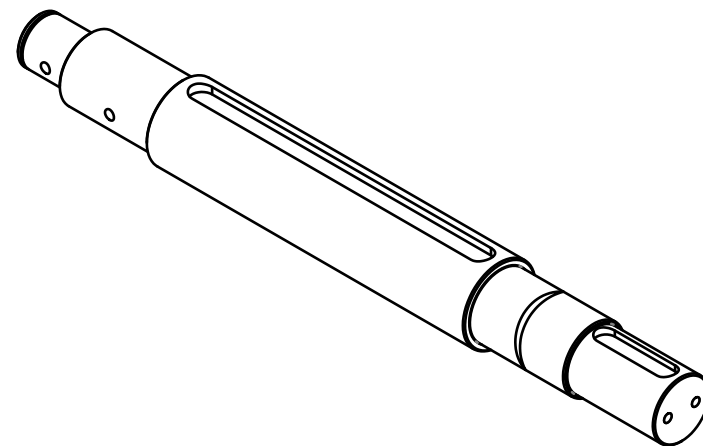
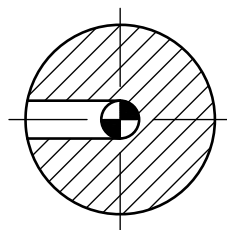

Technical requirement

1. Quenching and tempering HB220-255;
2. Undeclared fillet R0.5mm, unmarked chamfer 1X45° ;
3. The mutual displacement deviation between keyways shall not be greater than 0.1;
4. The deviation of the keyway width from the center shall not be greater than 0.025.

旧底图总号
底图总号
签字
日期

标记	处数	文件号	签字	日期
设计师	左昌生	所长		
主任设计师		绘图员		
成套主任		审图		
校核		日期	2023/2/20	

Shaft L

45

HNGK70207.4.1.8

共 1 张	单重(kg)	比例
第 1 张	11.84	1:1
底图编号		
山西海外高科技精密机械有限公司		