

# Design and Analysis of Robust H-infinity Controller

Ankit Bansal<sup>1</sup>, Veena Sharma<sup>2</sup>

Electrical Engineering Department, National Institute of Technology, Hamirpur (H.P.), India, 177005

E-mail: <sup>1</sup>[bansalankit125@gmail.com](mailto:bansalankit125@gmail.com), <sup>2</sup>[veenanaresh@gmail.com](mailto:veenanaresh@gmail.com)

## Abstract-

This paper presents a simplified step by step procedure for the design of  $H_\infty$  controller for a given system.  $H_\infty$  control synthesis is found to guarantee robustness and good performance. It provides high disturbance rejection, guaranteeing high stability for any operating conditions. H infinity controller can be designed using various techniques, but H infinity loop shaping finds wide acceptance since the performance requisites can be incorporated in the design stage as performance weights. Here this technique has been utilized to address some simple problems. Simulation results are given in the end to verify the validity of technique.

**Keywords:** H-infinity, loop shaping, weight selection, robust control, sensitivity

## 1. INTRODUCTION

Considerable advancement has been made in field of H infinity control synthesis since its inception by Zames. One can find a number of theoretical advantages of the methodology such as high disturbance rejection, high stability and many more. It has been widely used to address different practical and theoretical problems.

Mixed weight H Infinity controllers provide a closed loop response of the system according to the design specifications such as model uncertainty, disturbance attenuation at higher frequencies, required bandwidth of the closed loop plant etc. Practically, H Infinity controllers are of high order which, may lead to large control effort requirement. Moreover, the design may also depend on specific system and can require its specific analysis. When  $H_\infty$ -optimal control approach is applied to a plant, additional frequency dependent weights are incorporated in the plant and are selected to show particular stability and performance specifications relevant to the design objective defined in beginning.

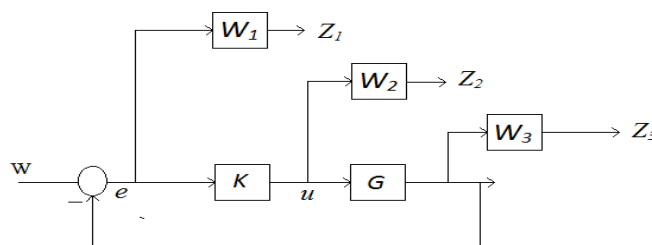

Figure 1: Classical feedback system structure with single weighting

Various techniques are available in literature for the design of H infinity controller and H infinity loop shaping is one of the widely accepted among them as the performance requirements can be embedded in the design stage as performance weights. The classical feedback system structure shown in Fig.1 establishes in general that weighing various loop signals in a way determined by the design specifications, the plant can be augmented possibly to produce useful closed loop transfer function tradeoffs. Here, a linear plant model is augmented with certain weight functions like sensitivity weight function, etc. so that desired performances of closed loop transfer function of the plant can be assured.

In this paper, we propose a simplified, step by step procedure for automatic weight selection algorithm for design of controller using H- infinity controller. Furthermore, the paper has been divided in two sections. Section 2 gives the short review of H- infinity controller and further design examples are given in section 3.

## 2. H INFINITY CONTROL

$H_\infty$  based robust control is proposed here, which deals with the characteristics such as amplifiers delay or sensors offset. First proposed by Zames, robust control theory addresses both the performance and stability criterion of a control system. Considering  $G(s)$  and  $K(s)$  as the open loop transfer function of the plant and controller transfer function respectively, this will ensure robustness and good performance of closed loop system. Controller  $K(s)$  can be derived, provided it follows three criterions, which are:

### 1.1 Stability criterion

If the roots of characteristic equation  $1 + G(s)K(s) = 0$  are in left half side of s plane, then stability is

ensured.

### 1.2 Performance Criterion

It establishes that the sensitivity  $S(s) = 1/(1 + G(s)K(s))$  is small for all frequencies where disturbances and set point changes are large.

### 1.3 Robustness criterion

It states that stability and performance should be maintained not only for the nominal model but also for a set of neighboring plant models that result from unavoidable presence of modeling errors. Robust  $H_\infty$  controllers are designed to ensure high robustness of linear systems.

Guangzhong Cao, Suxiang Fan, Gang Xu, Arredondo and J. Jugo, Zdzislaw Gosiewski, Arkadiusz Mystokowski, proposed the detailed design procedure for  $H_\infty$  control of linear system. Generally, the  $H_\infty$  norm of a transfer function,  $F$ , is its maximum value over the complete spectrum, and is represented as

$$\|F(j\omega)\|_\infty = \sup \sigma(F(j\omega)) \quad (1)$$

Here,  $\sigma$  is the largest singular value of a transfer function. The aim here is synthesize a controller which will ensure that the  $H_\infty$  norm of the plant transfer function is bounded within limits. Various techniques are there for the design of the  $H_\infty$  controllers such as two transfer function method and three transfer function method. The former one has less computational complexities and so can be preferred over the former one for  $H_\infty$  controller synthesis. The formulation of robust control problem is depicted in Fig. 2. Here, 'w' is the vector of all disturbance signals; 'z' is the cost signal consisting of all errors. 'v' is the vector consisting of measurement variables and 'u' is the vector of all control variables.

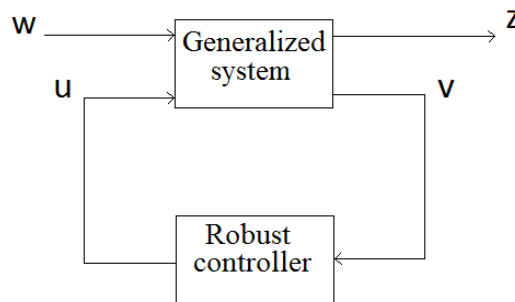

Figure 2: Robust Control Problem

Conventionally,  $H_\infty$  controller synthesis employs two transfer functions which divide a complex control problem into two separate sections, one dealing with stability, the other dealing with performance. The sensitivity function,  $S$ , and the complementary sensitivity function,  $T$ , which is required for the controller synthesis and are given in (2) and (3).

$$S = \frac{1}{1 + GK} \quad (2)$$

$$T = \frac{GK}{1 + GK} \quad (3)$$

Sensitivity function is the ratio of output to the disturbance of a system and complementary sensitivity function is the ratio of output to input of the system.

Now our objective is to find a controller  $K$ , which, based on the information in  $v$ , generates a control signal  $u$ , which counteracts the influence of  $w$  on  $z$ , thereby minimizing the closed loop norm  $w$  to  $z$ . This can be done by bounding the values of  $\sigma(S)$  for performance  $\sigma(T)$  for robustness. Minimizing the norm

$$\min_K \|N(K)\| \quad (4)$$

Where,

$$N = \begin{bmatrix} W_p S \\ W_s T \end{bmatrix} \quad (5)$$

$W_p$  and  $W_s$  are the weight functions to be specified by the designer. As we know that the ultimate objective of the robust control is to minimize the effect of disturbance on output, the sensitivity  $S$  and the complementary function  $T$  are to be reduced. To achieve this it is enough to minimize the magnitude of  $|S|$  and  $|T|$  which can be done so by making

$$|S(j\omega)| < \frac{1}{W_s(j\omega)} \text{ and } |T(j\omega)| < \frac{1}{W_t(j\omega)}$$

$W_s$  is the performance weighting function which limits the magnitude of the sensitivity function and  $W_t$  is the robustness weighting function to limit the magnitude of the complementary sensitivity function. Most widely used technique for selecting the weight functions for the synthesis of the controller is loop shaping technique.

As it is already known that the robust controller is designed so as to make the  $H_\infty$  norm of the plant to its minimum and so achieve this condition three weight functions are added to the plant for loop shaping. Basically, the weight functions are lead-lag compensators and can modify the frequency response of the system as desired. To obtain the desired frequency response for the plant, loop shaping is employed with the weight functions. There are various methods for loop shaping. The parameters of the weight functions are to be varied so as to get the frequency response of the whole system within desired limits. The block diagram in Fig. 3 describes the mixed Sensitivity problem.

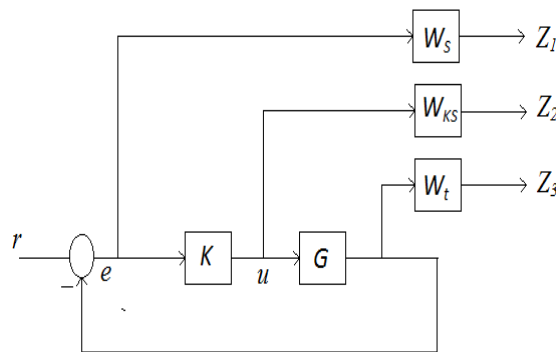

Figure 3: Plant model for the synthesis of  $H_\infty$  controller

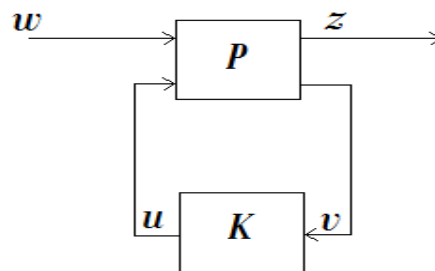

Figure 4: General control problem

The generalized plant  $P(s)$  is given as,

$$\begin{bmatrix} z_1 \\ z_2 \\ z_3 \\ e \end{bmatrix} = \begin{bmatrix} W_s & -W_s G \\ 0 & W_{ks} \\ 0 & W_t G \\ I & -G \end{bmatrix} \begin{bmatrix} w \\ u \end{bmatrix} \quad (6)$$

Considering the following state space realizations

$$G^s = \begin{bmatrix} A & B \\ C & D \end{bmatrix}, \quad W_s^s = \begin{bmatrix} A_s & B_s \\ C_s & D_s \end{bmatrix}, \quad W_{ks}^s = \begin{bmatrix} A_{ks} & B_{ks} \\ C_{ks} & D_{ks} \end{bmatrix}, \quad W_t^s = \begin{bmatrix} A_t & B_t \\ C_t & D_t \end{bmatrix},$$

a possible state space realization for  $P(s)$  can be written as

$$P = \begin{bmatrix} W_s & -W_s G \\ 0 & W_{ks} \\ 0 & W_t G \\ I & -G \end{bmatrix} = \begin{bmatrix} A & B_1 & B_1 \\ C_1 & D_{11} & D_{12} \\ C_2 & D_{21} & D_{22} \end{bmatrix} \quad (7)$$

From (6) and (7) we can write a mixed sensitivity problem as

$$P = \begin{bmatrix} W_s S \\ W_{ks} K S \\ W_t T \end{bmatrix} \quad (8)$$

In case of mixed sensitivity problem our objective is to find a rational function controller  $K(s)$  and to make the closed loop system stable satisfying the following expression

$$\min \|P\| = \min \begin{bmatrix} W_s S \\ W_{ks} K S \\ W_t T \end{bmatrix} = \gamma \quad (9)$$

where,  $P$  is the transfer function from  $w$  to  $Z$  i.e

$$\|T_{zw}\| = \gamma \quad (10)$$

where,  $\|T_{zw}\| = P$  is the cost function. Applying the minimum gain theorem, we can make the  $H_\infty$  norm of  $\|T_{zw}\|$  less than unity, i.e,

$$\min \|T_{zw}\| = \min \begin{bmatrix} W_s S \\ W_{ks} K S \\ W_t T \end{bmatrix} \leq 1 \quad (11)$$

Therefore we can achieve a stabilizing controller  $K(s)$  is achieved by solving the algebraic Riccati equations, thereby, minimizing the cost function  $\gamma$ .

As mentioned in the robust control theory the synthesis of the controller requires the selection of two weight functions. There are various methods available in literature for selection of weights. In most of these design methods the weighting functions are selected using trial and error and further the  $H_\infty$  controller is synthesized by loop shaping technique. But trial and error procedure may not end up in a stabilizing controller and this is the main drawback in this type of synthesis.

The weights  $W_s$ ,  $W_{ks}$  and  $W_t$  are the tuning parameters and it typically requires some iterations to obtain weights which will yield a good controller. That being said, a good starting point is to choose

$$W_s = \frac{s/M + \omega_0}{s + \omega_0 A} \quad (12)$$

$$W_{ks} = \text{const.} \quad (13)$$

$$W_t = \frac{s + \omega_0 / M}{As + \omega_0} \quad (14)$$

where  $A < 1$  is the maximum allowed steady state offset,  $\omega_0$  is the desired bandwidth and  $M$  is the sensitivity peak (typically  $A = 0.01$  and  $M = 2$ ). For the controller synthesis, the inverse of  $W_s$  is an upper bound on the desired sensitivity loop shape, and  $W_{ks}^{-1}$  will effectively limit the controller output  $u$  which is symmetric to  $W_s$  around the line  $\omega = \omega_0$ . Fig shows the two weighting functions for the parameter values  $A = 0.01$  ( $= -40\text{dB}$ ),  $M = 2$  ( $= 6\text{dB}$ ) and  $\omega_0 = 1$  rad/sec.

### 3. DESIGN EXAMPLE

#### 3.1 Example 1

Let the plant and nominal model are considered as follows:

$$\text{Plant} = \frac{85}{(s+1)(0.1s+2)^2}$$

The weighting functions designed by the algorithm are  $W_s$  serves to satisfy the control specification for the sensitivity characteristic and the response characteristic. Here it can be taken as

$$W_s = \frac{s+5}{s+5e-4}$$

and

$$W_{ks} = 1;$$

This produces the following controller

$$K(S) = \frac{4976 + 4.08e005s^6 + 1.274007s^5 + 1.835e008s^4 + 1.127e009s^3 + 1.752e009s^2 + 7.917e008s + 3.981e005}{s^8 + 6827s^7 + 7.039e005s^6 + 3.094e007s^5 + 6.211e008s^4 + 4.799e009s^3 + 4.212e009s^2 + 4.209e006s + 1060}$$

With GAMMA=1.2441

The largest singular value Bode plots of the closed-loop system are shown in Fig. 5. We note that the  $H_\infty$  controller typically gives a relatively flat frequency response since it tries to minimize the peak of the frequency response.

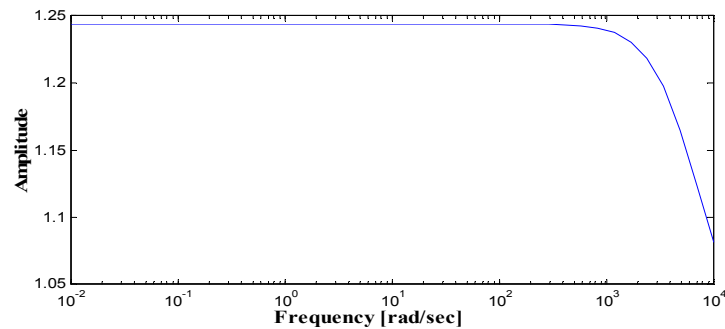

Figure 5: The largest singular value plot of the closed-loop System  $T_{z,w}$  with an  $H_\infty$  controller

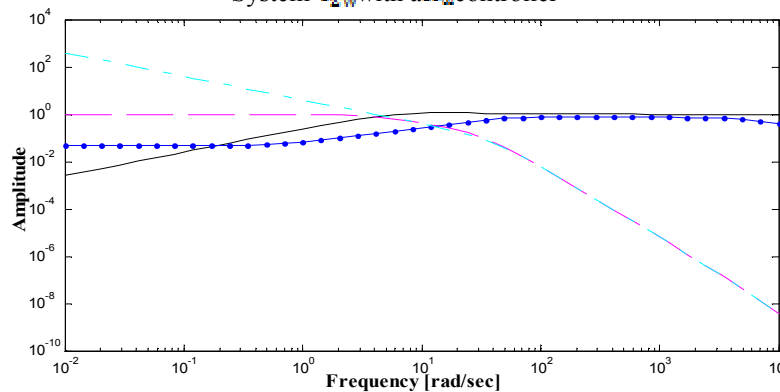

Figure 6: The frequency responses of S, T, KS and GK with K

Robust  $H_\infty$  controller developed not only operates on the known plant in a stable environment, but also provides good control for a set of nearby uncertain plants. The system must be robust enough to provide good performance and stability over the uncertainty. Singular values are a good measure of the system robustness. The Fig. 6 plots the singular value plot of the system with  $H_\infty$  control.

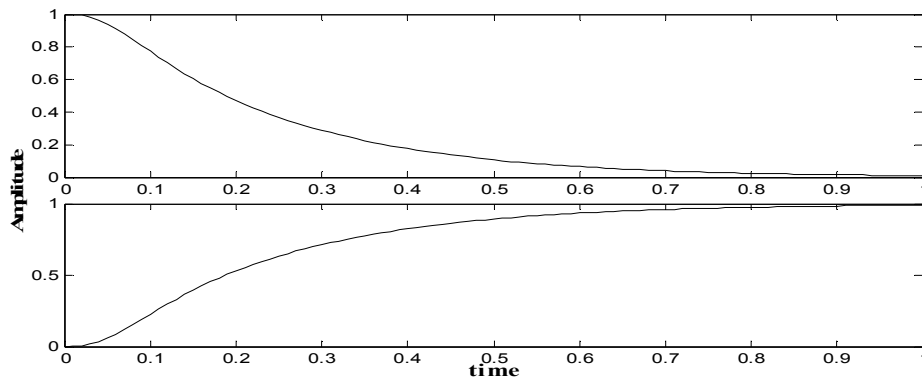

Figure 7: Step response

3.2 Example 2

The given plant model is,

$$\text{Plant} = \frac{39}{25s^2 + 7s - 4e005}$$

with the weight function as,

$$W(s) = \frac{s + 300}{3s + 15}$$

$$W(t) = \frac{s + 100}{s + 200}$$

Solving with the help of weight functions, we get the controller as,

$$K(s) = \frac{1.385e015s^3 + 5.016e017s^2 + 5.118e019s + 1.25e021}{s^4 + 7.537e006s^3 + 2.243e011s^2 + 6.926e014s + 3.457e015}$$

With GAMMA=0.7785

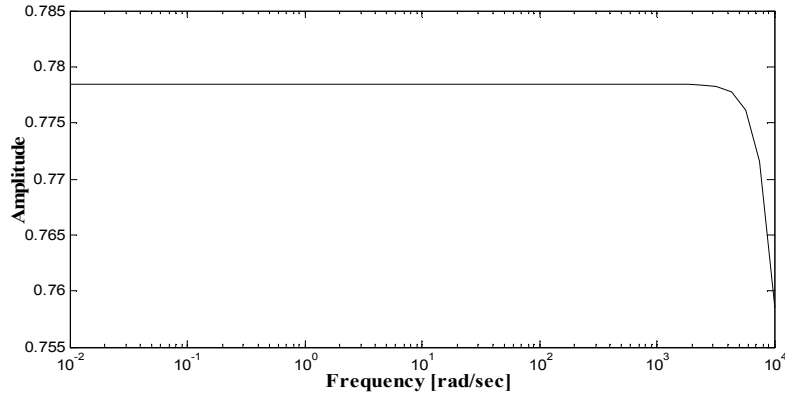

Figure 8: The largest singular value plot of the closed-loop System  $T_{zw}$  with a  $H_{\infty}$  controller

The largest singular value Bode plots of the closed-loopsystem are shown in Figure 8. We note that the  $H_{\infty}$  controller typically gives a relatively flat frequency response since it tries to minimize the peak of the frequency response.

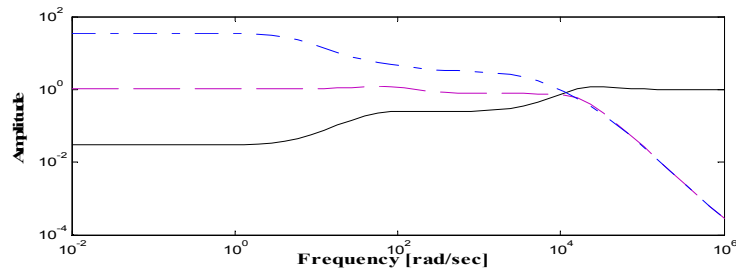

Figure 9: The frequency responses of S, T, and GK with K

Robust  $H_\infty$  controller developed not only operates on the known plant in a stable environment, but also provides good control for a set of nearby uncertain plants. The system must be robust enough to provide good performance and stability over the uncertainty. Singular values are a good measure of the system robustness. The Fig (9) plots the singular value plot of the system with  $H_\infty$  control.

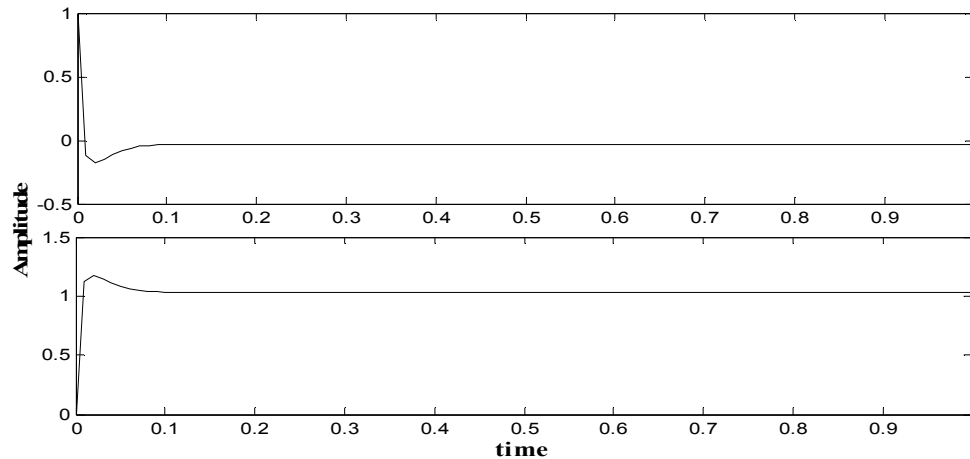

Figure 10: Step response

#### 4. CONCLUSION

A step-wise procedure for the design of  $H_\infty$  controller has been presented in detail in this paper. It has been observed from analysis that  $H_\infty$  controller guarantees robustness, good performance in terms of sensitivity and provides high disturbance rejection, providing high stability for any operating conditions. Simple illustrative examples have been considered and loop shaping technique has been utilized to solve the problems. Simulation results presented here verify the validity of loop shaping technique.

#### 5. REFERENCES

- [1]. Zames G., "Feedback of Optimal Sensitivity: Model Reference Transformations, Multiplicative Semi-norms, and Approximate Inverses", *IEEE Trans. AC*, Vol. AC-26, 1981, pp301-320.
- [2]. Limbeer, D.J.N. and Kasenally, E., 1986, " $H_\infty$  Optimal Control of a Synchronous Turbogenerator" in *Proc. IEEE 25th Conf. Decision Contr.* (Athens, Greece), Dec. 1986, pp 62-65.
- [3]. Doyle J. C., Glover K., Khargonekar P. P. and Francis B. A., State- Space Solutions to Standard  $H_2$  and  $H_\infty$  control problems, *Proc. 1988 American Control Conference*, Atlanta (1988).
- [4]. Glover K. and Doyle J.C., State-Space Formulae for all Stabilizing Controllers that Satisfy an  $H_\infty$ - Norm Bound and Relations to Risk Sensitivity, *Systems and Control Letters* 11, 167/172 (1988).
- [5]. Guangzhong Cao, Suxiang Fan, Gang Xu "The Characteristics Analysis of Magnetic Bearing Based on  $H_\infty$  Controller", *Proceedings of the 51th World Congress on Intelligent Control and Automation*, June 15-19, 2004, Hangzhou, P.R. China.
- [6]. Arredondo and J. Jugo, "Active Magnetic Bearings Robust Control Design based on Symmetry Properties", *Proceedings of the American Control Conference*, USA, July 11-13, 2007
- [7]. Beaven R.W., Wright M.T. and Seaward D.R., "Weighting function selection in the  $H_\infty$  design Process", *Control Eng. Practice*, Vol.4, No. 5, pp. 625-633, 1996
- [8]. Jiankun Hu, Christian Bohn, Wu H.R., "Systematic  $H_\infty$  weighting function selection and its application to the real-time control of a vertical take-off aircraft", *Control Engineering Practice* 8 (2000) 241-252
- [9]. Carl R. Knospe, "Active magnetic bearings for machining applications, *Control Engineering Practice* 15 (2007) 307-313
- [10]. Mark Siebert, Ben Ebihara, Ralph Jansen, Robert L. Fusaro and Wilfredo Morales, Albert Kascak, Andrew Kenny, "A Passive Magnetic Bearing Flywheel", NASA/TM—2002-211159, *36th Intersociety Energy Conversion Engineering Conference* cosponsored by the ASME, IEEE, AICHE, ANS, SAE, and AIAA Savannah, Georgia, July 29–August 2, 2001,
- [11]. Verde C. and Flores J., "Nominal model selection for robust control design", *proceedings of the American control conference*, seattle, Washington, 1996.
- [12]. Beaven W., Wright M.T. and Seaward D.R., "Weighting Function selection in the  $H_\infty$  design process", *control eng. practice*, vol. 4, no. 5, pp. 625-633, 1996
- [13]. Engell S., "Design of robust control systems with time-domain specifications", *control eng. practice*,

- vol. 3, no. 3, pp. 365-372, 1995
- [14]. DidierhEnrion, Michael Sebek and Sophie Tarbouriech, “Algebraic approach to robust controller design: A geometric interpretation”, *Proceedings of the American control conference*, philadelphia, pennsylvaniajune, 1998
- [15]. Jiang Z. F., Wu H. C., Lu H., Li C. R., “Study on the Controllability for Active Magnetic Bearings”, *Journal of Physics: Conference Series*13 (2005) 406–409
- [16]. Hochschulverlag A.G., Kokame H., Kobayashi H., Mori T., Robust  $H_{\infty}$  performance for linear delay-differential systems with time-varying uncertainties, *IEEE Trans. on Automatic Control*, Vol.43, No.2, 223-226, 1998.
- [17]. Euu T. J., Tong H. K., Hong B. P., H-infinityoutput feedback controller design for linear systems with time-varying delayed state, *IEEE Trans. on Automatic Control*, Vol.43, No.7, 971-974, 1998.
- [18]. Lee J. H., Lim S. W., Kwon W. H., Memoryless  $H_{\infty}$  controllers for state delayed systems, *IEEE Trans. on Automatic Control*, Vol.39, No.1, 159-162, 1994.
- [19]. Liu H. X., Xu B. G., Zhu X. F., Tang S. T., LMI Approach of  $H_{\infty}$  dynamic output feedback control for large-scale interconnected time-delay systems, *Journal of South China University of Technology*, Vol.29, No.11, 37-41, 2001.
- [20]. Doyle J. C., *Lecture Notes, in Adaances in Multivariable Control*, ONR/Honeywell Workshop, Minneapolis (1984)
- [21]. Francis B. A., *A Course in  $H_{\infty}$  control Theory*, Springer-Verlag (1987)
- [22]. Kimura H. and Kawatani R., Synthesis of  $H_{\infty}$  Controllers Based on Conjugation, *Proc.of CDC*, 7/13 (1988)
- [23]. Zhou K. and Khargonekar P. P., An Algebraic Riccati Equation Approach to  $H_{\infty}$  Optimization, *Systems and Control Letters* 11, 85/91 (1988)
- [24]. Sampei M., Mita T., Chida Y and Nakamichi M., A Direct Approach To  $H_{\infty}$  Control Problems Using Bounded Real Lemma, *Conference on Decision and Control*, Florida (1989)
- [25]. Nair S. Sarath, Automatic weight Selection Algorithm for Designing H-Infinity controller for Active Magnetic Bearing, *International Journal of Science and Technology (IJEST)*, Vol. 3, No. 1, Jan 2011.
- [26]. Hvostov S. Harry, Simplifying H-Infinity Controller Synthesis via Classical feedback System Structure, *Proceeding of the 28<sup>th</sup> Conference on Decision and Control*, Tampa, Florida, Dec,1989



This academic article was published by The International Institute for Science, Technology and Education (IISTE). The IISTE is a pioneer in the Open Access Publishing service based in the U.S. and Europe. The aim of the institute is Accelerating Global Knowledge Sharing.

More information about the publisher can be found in the IISTE's homepage:

<http://www.iiste.org>

## CALL FOR PAPERS

The IISTE is currently hosting more than 30 peer-reviewed academic journals and collaborating with academic institutions around the world. There's no deadline for submission. **Prospective authors of IISTE journals can find the submission instruction on the following page:** <http://www.iiste.org/Journals/>

The IISTE editorial team promises to review and publish all the qualified submissions in a **fast** manner. All the journals articles are available online to the readers all over the world without financial, legal, or technical barriers other than those inseparable from gaining access to the internet itself. Printed version of the journals is also available upon request of readers and authors.

### IISTE Knowledge Sharing Partners

EBSCO, Index Copernicus, Ulrich's Periodicals Directory, JournalTOCS, PKP Open Archives Harvester, Bielefeld Academic Search Engine, Elektronische Zeitschriftenbibliothek EZB, Open J-Gate, OCLC WorldCat, Universe Digital Library, NewJour, Google Scholar

