

## APPENDICES

## APPENDIX - A

## DATA FOR IEEE-30 BUS TEST SYSTEM

The one line diagram of an IEEE-30 bus system is shown in Fig. A.1. The System data is taken from references [147] [149]. The line data, bus data and load flow results are given in Tables A.1 and A.2, respectively. The generator cost and emission coefficients, transformer tap setting, shunt capacitor data are provided in Table A.3, A.4 and A.5, respectively. The B-loss coefficients matrix of the system is given in Table A.6. The data is on 100 MVA base.

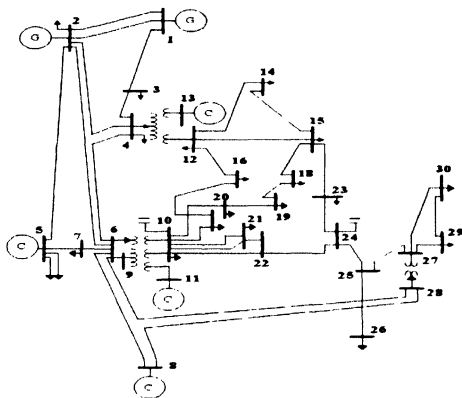

Fig. A.1. One line diagram

Table A.1. Line data

Line No.	From Bus	To Bus	Line Impedance		Half Line Charging Susceptance (p.u.)	MVA Rating
			Resistance (p.u.)	Reactance (p.u.)		
1	1	2	0.0192	0.0575	0.0264	130
2	1	3	0.0452	0.1652	0.0204	130
3	2	4	0.0570	0.1737	0.0184	65
4	3	4	0.0132	0.0379	0.0042	130
5	2	5	0.0472	0.1983	0.0209	130
6	2	6	0.0581	0.1763	0.0187	65
7	4	6	0.0119	0.0414	0.0045	90
8	5	7	0.0460	0.1160	0.0102	70
9	6	7	0.0267	0.0820	0.0085	130
10	6	8	0.0120	0.0420	0.0045	32
11	6	9	0	0.2080	0	65
12	6	10	0	0.5560	0	32
13	9	11	0	0.2080	0	65
14	9	10	0	0.1100	0	65
15	4	12	0	0.2560	0	65
16	12	13	0	0.1400	0	65
17	12	14	0.1231	0.2559	0	32
18	12	15	0.0662	0.1304	0	32
19	12	16	0.0945	0.1987	0	16
20	14	15	0.2210	0.1997	0	16
21	16	17	0.0524	0.1923	0	16
22	15	18	0.1073	0.2185	0	16
23	18	19	0.0639	0.1292	0	16
24	19	20	0.0340	0.0680	0	16
25	10	20	0.0936	0.2090	0	32

26	10	17	0.0324	0.0845	0	32
27	10	21	0.0348	0.0749	0	32
28	10	22	0.0727	0.1499	0	32
29	21	22	0.0116	0.0236	0	32
30	15	23	0.1000	0.2020	0	16
31	22	24	0.1150	0.1790	0	16
32	23	24	0.1320	0.2700	0	16
33	24	25	0.1885	0.3292	0	16
34	25	26	0.2544	0.3800	0	16
35	25	27	0.1093	0.2087	0	16
36	28	27	0	0.3960	0	65
37	27	29	0.2198	0.4153	0	16
38	27	30	0.3202	0.6027	0	16
39	29	30	0.2399	0.4533	0	26
40	8	28	0.0636	0.2000	0.0214	32
41	6	28	0.0169	0.0599	0.0065	32

Table A.2. Bus data and Load flow results

Bus No.	Bus Voltage		Generation		Load		Reactive Power Limits	
	Magnitude (p.u.)	Phase Angle (degrees)	Real Power (p.u.)	Reactive Power (p.u.)	Real Power (p.u.)	Reactive Power (p.u.)	$Q_{min}$ (p.u.)	$Q_{max}$ (p.u.)
1	1.06	0.000	1.3848	-0.0279	0.000	0.000	-	-
2	1.045	0.000	0.4	0.5	0.217	0.127	-0.2	0.6
3	1.000	0.000	0.000	0.000	0.024	0.012	-	-
4	1.060	0.000	0.000	0.000	0.076	0.016	-	-
5	1.010	0.000	0.000	0.37	0.942	0.19	-0.15	0.625
6	1.000	0.000	0.000	0.000	0.000	0.000	-	-
7	1.000	0.000	0.000	0.000	0.228	0.109	-	-
8	1.010	0.000	0.000	0.373	0.3	0.3	-0.15	0.50
9	1.000	0.000	0.000	0.000	0.000	0.000	-	-
10	1.000	0.000	0.000	0.000	0.058	0.02	-	-
11	1.082	0.000	0.000	0.162	0.000	0.000	-0.10	0.40
12	1.000	0.000	0.000	0.000	0.112	0.075	-	-
13	1.071	0.000	0.000	0.106	0.000	0.000	-0.15	0.45
14	1.000	0.000	0.000	0.000	0.062	0.016	-	-
15	1.000	0.000	0.000	0.000	0.082	0.025	-	-
16	1.000	0.000	0.000	0.000	0.035	0.018	-	-
17	1.000	0.000	0.000	0.000	0.09	0.058	-	-
18	1.000	0.000	0.000	0.000	0.032	0.009	-	-
19	1.000	0.000	0.000	0.000	0.095	0.034	-	-

20	1.000	0.000	0.000	0.000	0.022	0.007	-	-
21	1.000	0.000	0.000	0.000	0.175	0.112	-	-
22	1.000	0.000	0.000	0.000	0.000	0.000	-	-
23	1.000	0.000	0.000	0.000	0.032	0.016	-	-
24	1.000	0.000	0.000	0.000	0.087	0.067	-	-
25	1.000	0.000	0.000	0.000	0.000	0.000	-	-
26	1.000	0.000	0.000	0.000	0.035	0.023	-	-
27	1.000	0.000	0.000	0.000	0.000	0.000	-	-
28	1.000	0.000	0.000	0.000	0.000	0.000	-	-
29	1.000	0.000	0.000	0.000	0.024	0.009	-	-
30	1.000	0.000	0.000	0.000	0.106	0.019	-	-

**Table A.3. Generator cost and Emission coefficients**

Unit	$P_i^{\min}$ (MW)	$P_i^{\max}$ (MW)	$a_i$ (\$/MWh <sup>2</sup> )	$b_i$ (\$/MWh)	$c_i$	$\alpha_i$ (Kg/MWh <sup>2</sup> )	$\beta_i$ (Kg/MWh)	$\gamma_i$
1	50	200	0.00375	2.00	0	0.0126	-1.1000	22.983
2	20	80	0.01750	1.75	0	0.0200	-0.1000	22.313
5	15	50	0.06250	1.00	0	0.0270	-0.1000	25.505
8	10	35	0.00834	3.25	0	0.0291	-0.0050	24.900
11	10	30	0.02500	3.00	0	0.0290	-0.0400	24.700
13	12	40	0.02500	3.00	0	0.0271	-0.0055	25.300

**Table A.4. Transformer tap setting data**

From Bus	To Bus	Tap Setting Value(p.u)
6	9	0.978
6	10	0.969
4	12	0.932
28	27	0.968

**Table A.5. Shunt capacitor data**

Bus No.	Susceptance (p.u.)
10	0.19
24	0.043

**Table A.6. Generalized loss coefficients**

$$B_{ij} = \begin{bmatrix} 0.000218 & 0.000103 & 0.000009 & -0.000010 & 0.000002 & 0.000027 \\ 0.000103 & 0.000181 & 0.000004 & -0.000015 & 0.000002 & 0.000030 \\ 0.000009 & 0.000004 & 0.000417 & -0.000131 & -0.000153 & -0.000107 \\ -0.000010 & -0.000015 & -0.000131 & 0.000221 & 0.000094 & 0.000050 \\ 0.000002 & 0.000002 & -0.000153 & 0.000094 & 0.000243 & -0.000000 \\ 0.000027 & 0.000030 & -0.000107 & 0.000050 & -0.000000 & 0.000358 \end{bmatrix}$$

$$B_{0i} = [-0.000003 \quad 0.000021 \quad -0.000056 \quad 0.000034 \quad 0.000015 \quad 0.000078]$$

$$B_{00} = [0.000014]$$

## APPENDIX – B

### DATA FOR 6 UNIT TEST SYSTEM

The system contains six thermal units, 26 buses, and 46 transmission lines [42]. The load demand is 1263 MW. The cost coefficients of 6 unit test system are given in Tables B.1. The ramp rate limits of corresponding generating units are given in Table B.2. The generalized B loss coefficients for the system are shown Table B.3. The system data is on 100 MVA base.

**Table B.1. Generating Unit Capacity and Coefficients**

Unit	$P_i^{\min}$ (MW)	$P_i^{\max}$ (MW)	$a_i$ (\$/MWh <sup>2</sup> )	$b_i$ (\$/MWh)	$c_i$
1	100	500	0.0070	7.0	240
2	50	200	0.0095	10.0	200
3	80	300	0.0090	8.5	220
4	50	150	0.0090	11.0	200
5	50	200	0.0080	10.5	220
6	50	120	0.0075	12.0	190

**Table B.2. Ramp Rate Limits and Prohibited Operating Zones**

Unit	$P_i^0$ (MW)	$UR_i$ (MW/h)	$DR_i$ (MW/h)	Prohibited Zones (MW)
1	440	80	120	[210 240] [350 380]
2	170	50	90	[90 110] [140 160]
3	200	65	100	[150 170] [210 240]
4	150	50	90	[80 90] [110 120]
5	190	50	90	[90 110] [140 150]
6	110	50	90	[75 85] [100 105]

**Table B.3. Generalized loss coefficients**

$$B_v = \begin{bmatrix} 0.0017 & 0.0012 & 0.0007 & -0.0001 & -0.0005 & -0.0002 \\ 0.0012 & 0.0014 & 0.0009 & 0.0001 & -0.0006 & -0.0001 \\ 0.0007 & 0.0009 & 0.0031 & 0.0000 & -0.0010 & -0.0006 \\ -0.0001 & 0.0001 & 0.00000 & 0.0024 & -0.0006 & -0.0008 \\ -0.0005 & -0.0006 & -0.0010 & -0.0006 & 0.0129 & -0.0002 \\ -0.0002 & -0.0001 & -0.0006 & -0.0008 & -0.0002 & 0.0150 \end{bmatrix}$$

$$B_{o1} = 1.0 e^{-03} [-0.3908 \quad -0.1297 \quad 0.7047 \quad 0.0591 \quad 0.2161 \quad -0.6635]$$

$$B_{oo} = 0.056$$



## APPENDIX – C

### DATA FOR 15-UNIT TEST SYSTEM

The 15-unit test system contains 15 thermal units whose characteristics are given in Tables C.1, C.2, respectively. The generalized loss coefficients are given Table C.3. The system data is taken from reference [42].

**Table C.1. Generating unit with ramp rate limits**

Unit	$P_i^{\min}$ (MW)	$P_i^{\max}$ (MW)	$c_i$	$b_i$ (\$/MWh)	$a_i$ (\$/MWh <sup>2</sup> )	$UR_i$ (MW/h)	$DR_i$ (MW/h)	$P_i^0$ (MW)
1	150	455	671	10.1	0.000299	80	120	400
2	150	455	574	10.2	0.000183	80	120	300
3	20	130	374	8.8	0.001126	130	130	105
4	20	130	374	8.8	0.001126	130	130	100
5	150	470	461	10.4	0.000205	80	120	90
6	135	460	630	10.1	0.000301	80	120	400
7	135	465	548	9.8	0.000364	80	120	350
8	60	300	227	11.2	0.000338	65	100	95
9	25	162	173	11.2	0.000807	60	100	105
10	25	160	175	10.7	0.001203	60	100	110
11	20	80	186	10.2	0.003586	80	80	60
12	20	80	230	9.9	0.005513	80	80	40
13	25	85	225	13.1	0.000371	80	80	30
14	15	55	309	12.1	0.001929	55	55	20
15	15	55	323	12.4	0.004447	55	55	20

**Table C.2. Prohibited operating zones of generating units**

Unit	Prohibited Zones (MW)
2	[185 225] [305 335] [420 450]
5	[180 200] [305 335] [390 420]
6	[230 255] [365 395] [430 455]
12	[30 40] [55 65]

**Table C.3. Generalized loss coefficients**

$$B_{ij} = \begin{pmatrix} 0.0014 & 0.0012 & 0.0007 & -0.0001 & -0.0003 & -0.0001 & -0.0001 & -0.0001 & -0.0003 & 0.0005 & -0.0003 & -0.0002 & 0.0004 & 0.0003 & -0.0001 \\ 0.0012 & 0.0013 & 0.0013 & 0.0000 & -0.0005 & -0.0002 & 0.0000 & 0.0001 & -0.0002 & -0.0004 & -0.0004 & -0.0000 & 0.0004 & 0.0010 & -0.0002 \\ 0.0007 & 0.0000 & 0.0076 & -0.0001 & -0.0013 & -0.0009 & -0.0001 & 0.0000 & -0.0008 & -0.0012 & -0.0017 & -0.0000 & -0.0025 & 0.0111 & -0.0028 \\ -0.0001 & -0.0005 & -0.0001 & 0.0034 & -0.0007 & -0.0004 & 0.0011 & 0.0050 & 0.0029 & 0.0032 & -0.0011 & -0.0000 & 0.0001 & 0.0001 & -0.0026 \\ -0.0003 & -0.0002 & -0.0013 & -0.0007 & 0.0090 & 0.0014 & -0.0003 & -0.0012 & -0.0010 & -0.0013 & 0.0007 & -0.0002 & -0.0002 & -0.0024 & -0.0003 \\ -0.0001 & 0.0000 & -0.0009 & -0.0004 & 0.0014 & 0.0016 & -0.0000 & -0.0006 & -0.0005 & -0.0008 & 0.0011 & -0.0001 & -0.0002 & -0.0017 & 0.0003 \\ -0.0001 & 0.0000 & -0.0001 & 0.0011 & -0.0003 & -0.0000 & 0.0015 & 0.0017 & 0.0016 & 0.0009 & -0.0006 & 0.0007 & -0.0000 & -0.0002 & -0.0008 \\ -0.0001 & 0.0001 & 0.0000 & 0.0050 & -0.0012 & -0.0006 & 0.0017 & 0.0168 & 0.0082 & 0.0079 & -0.0023 & -0.0036 & 0.0001 & 0.0006 & -0.0078 \\ -0.0003 & -0.0002 & -0.0008 & 0.0029 & -0.0010 & -0.0005 & 0.0015 & 0.0082 & 0.0129 & 0.0116 & -0.0021 & -0.0025 & 0.0007 & -0.0012 & -0.0072 \\ -0.0003 & -0.0004 & -0.0012 & 0.0032 & -0.0013 & -0.0008 & 0.0009 & 0.0079 & 0.0116 & 0.0200 & -0.0027 & -0.0034 & 0.0009 & -0.0011 & -0.0088 \\ -0.0003 & -0.0004 & -0.0017 & -0.0011 & 0.0007 & 0.0011 & -0.0005 & -0.0023 & -0.0021 & -0.0027 & 0.0140 & 0.0001 & 0.0004 & -0.0038 & 0.0168 \\ -0.0002 & -0.0000 & -0.0000 & -0.0000 & -0.0002 & -0.0001 & 0.0007 & -0.0036 & -0.0025 & -0.0034 & 0.0001 & 0.0064 & -0.0001 & -0.0004 & 0.0028 \\ 0.0004 & 0.0001 & -0.0025 & 0.0001 & -0.0002 & -0.0002 & -0.0000 & 0.0001 & 0.0007 & 0.0009 & 0.0004 & -0.0001 & 0.0130 & -0.0101 & 0.0028 \\ 0.0003 & 0.0010 & 0.0111 & 0.0001 & -0.0024 & -0.0017 & -0.0002 & 0.0005 & -0.0012 & -0.0011 & -0.0038 & -0.0004 & -0.0101 & 0.0678 & -0.0094 \\ -0.0001 & -0.0002 & -0.0028 & -0.0026 & -0.0003 & 0.0003 & -0.0008 & -0.0078 & -0.0072 & -0.0088 & 0.0168 & 0.0028 & 0.0028 & -0.0094 & 0.1283 \end{pmatrix}$$

$$B_{ii} = \begin{pmatrix} -0.0001 & -0.0002 & 0.0028 & -0.0001 & 0.0001 & -0.0003 & -0.0002 & -0.0002 & 0.0006 & 0.0039 & -0.0017 & -0.0000 & -0.0032 & 0.0067 & -0.0064 \end{pmatrix}$$

$$B_{10} = 0.0055$$

## APPENDIX – D

## DATA FOR TAIPOWER 40-UNIT SYSTEM

The system data is taken from reference [50] whose characteristics are given in Table D.1. The data is on 100 MVA base.

Table D.1. Generating units coefficients with ramp rate limits

Unit	$P_i^{\min}$ (MW)	$P_i^{\max}$ (MW)	$a_i$ (\$/MWh <sup>2</sup> )	$b_i$ (\$/MWh)	$c_i$	$UR_i$ (MW/h)	$DR_i$ (MW/h)
1	40	80	0.03073	8.336	170.44	35	60
2	60	120	0.02028	7.0706	309.54	40	70
3	80	190	0.00942	8.1817	369.03	50	90
4	24	42	0.08482	6.9467	135.48	42	42
5	26	42	0.09693	6.5595	135.19	42	42
6	68	140	0.01142	8.0543	222.23	40	75
7	110	300	0.00357	8.0323	287.71	65	100
8	135	300	0.00492	6.999	391.98	65	100
9	135	300	0.00573	6.602	455.76	65	100
10	130	300	0.00605	12.908	722.82	65	100
11	94	375	0.00515	12.986	635.2	55	95
12	94	375	0.00569	12.796	654.69	55	95
13	195	500	0.00421	12.501	913.4	80	120
14	195	500	0.00752	8.8412	1760.4	80	120
15	195	500	0.00708	9.1575	1728.3	80	120
16	195	500	0.00708	9.1575	1728.3	80	120
17	195	500	0.00708	9.1575	1728.3	80	120
18	220	500	0.00313	7.9691	647.85	70	110
19	220	500	0.00313	7.955	649.69	70	110
20	242	550	0.00313	7.9691	647.83	70	110
21	242	550	0.00313	7.9691	647.81	70	110
22	254	550	0.00298	6.6313	785.96	70	110

23	254	550	0.00298	6.6313	785.96	70	110
24	254	550	0.00284	6.6611	794.53	70	110
25	254	550	0.00284	6.6611	794.53	70	110
26	254	550	0.00277	7.1032	801.32	70	110
27	254	550	0.00277	7.1032	801.32	70	110
28	10	150	0.52124	3.3353	1055.1	90	150
29	10	150	0.52124	3.3353	1055.1	90	150
30	10	150	0.52124	3.3353	1055.1	90	150
31	20	70	0.25098	13.052	1207.8	70	70
32	20	70	0.16766	21.887	810.79	70	70
33	20	70	0.2635	10.244	1247.7	70	70
34	20	70	0.30575	8.3707	1219.2	70	70
35	18	60	0.18362	26.258	641.43	60	60
36	18	60	0.32563	9.6956	1112.8	60	60
37	20	60	0.33722	7.1633	1044.4	60	60
38	25	60	0.23915	16.339	832.24	60	60
39	25	60	0.23915	16.339	834.24	60	60
40	25	60	0.23915	16.339	1035.2	60	60

## APPENDIX – E

### LINE VOLTAGE STABILITY INDEX

The important aspect of voltage stability assessment is to find the distance (MW/MVAR/MVA) to maximum loadability point from the present operating point [115]. Line voltage stability index is used to get accurately the proximity of the operating point to voltage collapse point by the index given as follows. Let us consider a single line of an interconnected network, where the lines are connected through a grid network. Any of the lines from that network can be considered to have the following parameters as shown in Fig. E.1. Utilizing the concept of power flow in the line and analyzing with ‘ $\Pi$ ’ model representation, the real and reactive power flow equations in terms of transmission line constants are formulated

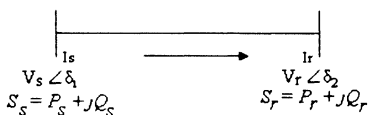

**Fig. E.1. One line diagram of a typical transmission system**

Loads are more often expressed in terms of real (Watts/KW) and reactive (VArS/KVAr) power. Therefore, it is convenient to deal with transmission line equation in the form of sending and receiving end complex power and voltage.

Let us treat receiving end voltage as a reference phasor ( $V_R = |V_R| \angle 0$ ) and let the sending end voltage lead it by an angle  $\delta$  ( $V_S = |V_S| \angle \delta$ ). Transmission lines are normally operated with a balanced 3 phase load. The analysis can be therefore performed on per phase basis.

The complex power leaving the sending- end and entering the receiving end of the transmission line can be expressed on per phase basis [154], as

$$\left. \begin{aligned} S_R &= P_R + jQ_R = V_R I_R^* \\ S_S &= P_S + jQ_S = V_S I_S^* \end{aligned} \right\} \quad (E.1)$$

A transmission line on a per phase basis, can be regarded as a two-port network, where in the sending end voltage,  $V_s$  and current,  $I_s$  are related to the receiving end voltage,  $V_R$  and current,  $I_R$  through ABCD constants [154] as

$$\begin{bmatrix} V_s \\ I_s \end{bmatrix} = \begin{bmatrix} A & B \\ C & D \end{bmatrix} \begin{bmatrix} V_R \\ I_R \end{bmatrix} \quad (\text{E.2})$$

Receiving and sending end currents can be expressed in terms of receiving and sending end voltages [154] as

$$I_R = \frac{1}{B} V_s - \frac{A}{B} V_R \quad (\text{E.3})$$

$$I_s = \frac{D}{B} V_s - \frac{1}{B} V_R \quad (\text{E.4})$$

Let A, B, D the transmission line constants [154] be written as

$$A = |A| \angle \alpha_1, \quad B = |B| \angle \beta_1, \quad D = |D| \angle \alpha_1 \quad (\text{Since } A = D)$$

Therefore we can write,

$$I_R = \frac{1}{|B|} |V_s| \angle (\delta - \beta_1) - \frac{|A|}{|B|} \angle (\alpha - \beta_1) \quad (\text{E.5})$$

$$I_s = \frac{|D|}{|B|} |V_s| \angle ((\alpha_1 + \delta) - \beta_1) - \frac{|A|}{|B|} \angle -\beta_1 \quad (\text{E.6})$$

Substituting for  $I_R$  in equation (E.1) we get,

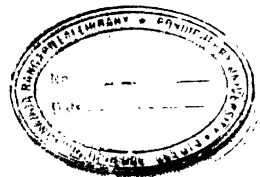

$$S_R = V_R \angle 0 \left[ \frac{1}{|B|} |V_S| \angle (\beta_1 - \delta) - \frac{A}{|B|} |V_R| \angle (\beta_1 - \alpha_1) \right] \quad (\text{E.7})$$

$$S_R = \frac{|V_S||V_R|}{|B|} \angle (\beta_1 - \delta) - \frac{A}{|B|} |V_R|^2 \angle (\beta_1 - \alpha_1) \quad (\text{E.8})$$

Similarly

$$S_S = \frac{|D|}{|B|} |V_S|^2 \angle (\beta_1 - \alpha_1) - \frac{|V_S||V_R|}{|B|} \angle (\beta_1 + \alpha_1) \quad (\text{E.9})$$

If equation (E.8) is expressed in real and imaginary parts, we can write the real and reactive powers at the receiving end [154] as,

$$P_R = \frac{V_S V_R}{B} \cos(\beta_1 - \delta) - \frac{A}{B} V_R^2 \cos(\beta_1 - \alpha_1) \quad (\text{E.10})$$

$$Q_R = \frac{V_S V_R}{B} \sin(\beta_1 - \delta) - \frac{A}{B} V_R^2 \sin(\beta_1 - \alpha_1) \quad (\text{E.11})$$

where  $A \angle \alpha_1$  and  $B \angle \beta_1$  are the transmission line constants

For the usual  $\pi$ -model, the transmission line constants may be written as follows

$$\begin{aligned} A &= 1 + \frac{ZY}{2} \\ B &= Z \end{aligned} \quad (\text{E.12})$$

If the length of the line is medium, then

$Z$  is the total series impedance of line,

$Y$  is the total line charging susceptance.

If it is a long transmission line, then

$$A = 1 + \frac{Z'Y'}{2} \quad (\text{E.13})$$

$$B = Z'$$

where

$$Z' = Z \left( \frac{\sinh \gamma l}{\gamma l} \right) \quad (\text{E.14})$$

$$\frac{Y'}{2} = \frac{Y}{2} \left[ \frac{\tanh \gamma \frac{l}{2}}{\gamma \frac{l}{2}} \right] \quad (\text{E.15})$$

$\gamma$  is propagation constant and  $l$  is the length of transmission line.

The formulae for the receiving end real and reactive powers can be formulated as follows [154]

$$P_R = \frac{E_R |E_S|}{|B|} \cos(\beta_1 - \delta) - \frac{E_R^2 |A|}{|B|} \cos(\beta_1 - \alpha_1) \quad (\text{E.16})$$

$$Q_R = \frac{E_R |E_S|}{|B|} \sin(\beta_1 - \delta) - \frac{E_R^2 |A|}{|B|} \sin(\beta_1 - \alpha_1) \quad (\text{E.17})$$

These can be rewritten as,

$$P_R + \frac{E_R^2 |A|}{|B|} \cos(\beta_1 - \alpha_1) = \frac{E_R |E_S|}{|B|} \cos(\beta_1 - \delta) \quad (\text{E.18})$$

$$Q_R + \frac{E_R^2 |A|}{|B|} \sin(\beta_1 - \alpha_1) = \frac{E_R |E_S|}{|B|} \sin(\beta_1 - \delta) \quad (\text{E.19})$$

Then by eliminating  $\delta$ , by squaring and adding the two equations, we obtain the locus of  $P_R$  against  $Q_R$  to be a circle with given values of  $A$  and  $B$  and for assumed values of  $E_R$  and  $|E_S|$  to be [154] as follows.

$$\left\{ P_R + \frac{E_R^2 |A|}{|B|} \cos(\beta_1 - \alpha_1) \right\}^2 + \left\{ Q_R + \frac{E_R^2 |A|}{|B|} \sin(\beta_1 - \alpha_1) \right\}^2 = \left[ \frac{E_R |E_S|}{|B|} \right]^2 \quad (\text{E.20})$$

If  $k^{\text{th}}$  bus is the sending end and  $m^{\text{th}}$  bus is the receiving end and expanding the above equation we get as follows,

$$P_m^2 + \frac{A^2}{B^2} V_m^4 \cos^2(\beta_1 - \alpha_1) + 2P_m \frac{A}{B} V_m^2 \cos(\beta_1 - \alpha_1) + Q_m^2 + \frac{A^2}{B^2} V_m^4 \sin^2(\beta_1 - \alpha_1) \\ + 2Q_m \frac{A}{B} V_m^2 \sin(\beta_1 - \alpha_1) = \frac{V_k^2 V_m^2}{B^2}$$



$$V_m^4 \frac{A^2}{B^2} + V_m^2 \frac{A}{B} (2P_m \cos(\beta_1 - \alpha_1) + V_m^2 \frac{A}{B} (2Q_m \sin(\beta_1 - \alpha_1) + P_m^2 + Q_m^2) = \frac{V_k^2 V_m^2}{B^2} \quad (\text{E.21})$$

$$\begin{aligned} V_m^4 + V_m^2 \frac{B}{A} (2P_m \cos(\beta_1 - \alpha_1) + V_m^2 \frac{B}{A} (2Q_m \sin(\beta_1 - \alpha_1) \\ + (P_m^2 + Q_m^2) \frac{B^2}{A^2} = \frac{V_k^2 V_m^2}{A^2} \\ V_m^4 - \left\{ \frac{V_k^2}{A^2} - 2 \frac{B}{A} P_m \cos(\beta_1 - \alpha_1) - 2 \frac{B}{A} Q_m \sin(\beta_1 - \alpha_1) \right\} \\ V_m^2 + (P_m^2 + Q_m^2) \frac{B^2}{A^2} = 0 \end{aligned} \quad (\text{E.22})$$

The above equation should have the real roots for  $V_m$  for the system to be stable. Hence the following condition should be satisfied [154].

$$LS_1 = \frac{2 \frac{B}{A} \sqrt{(P_m^2 + Q_m^2)}}{\frac{V_k^2}{A^2} - 2 \frac{B}{A} P_m \cos(\beta_1 - \alpha_1) - 2 \frac{B}{A} Q_m \sin(\beta_1 - \alpha_1)} \leq 1 \quad (\text{E.23})$$

where,  $LS_1$  is termed as voltage stability index of the line  $P_m$  and  $Q_m$  are the real and reactive power received at the receiving end  $m$ ,  $A \angle \alpha_1$  and  $B \angle \beta$  are the transmission line constants,  $V_k$  and  $V_m$  are the voltages at the sending end bus  $k$  and receiving end bus  $m$ .

At or near the collapse point, voltage stability index of one or more line approach to unity. This method is used to assess the voltage stability.

## APPENDIX – F

### STANDARD – 5 BUS SYSTEM

The Standard 5 bus system is shown in Fig. F.1. The System data is taken from reference [154]. The line data and bus data are given in Tables F.1, F.2, respectively. The data is on 100 MVA base.

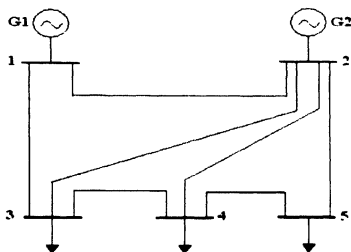

Fig. F.1. One line diagram

Table F.1. Line data

Line No.	From Bus	To Bus	Line Impedance		Half Line Charging Admittance (p.u.)
			Resistance (p.u.)	Reactance (p.u.)	
1	1	2	0.02	0.06	0.030
2	1	3	0.08	0.24	0.025
3	2	3	0.06	0.18	0.020
4	2	4	0.02	0.18	0.020
5	2	5	0.04	0.12	0.015
6	3	4	0.01	0.03	0.010
7	4	5	0.08	0.24	0.035

Table F.2. Bus Data

Bus No.	Bus Voltage		Generation		Load	
	Magnitude (p.u.)	Phase angle (degrees)	Real power (p.u.)	Reactive power (p.u.)	Real power (p.u.)	Reactive power (p.u.)
1	1.06	0.00	-	-	-	-
2	1.01	0.00	0.2	-	0.00	0.1
3	1.0	0.00	-	-	0.45	0.15
4	1.0	0.00	-	-	0.4	0.05
5	1.0	0.00	-	-	0.6	0.1

## APPENDIX – G

### DATA FOR IEEE-14 BUS TEST SYSTEM

The one line diagram of an IEEE-14 bus system is shown in Fig. G.1. The System data is taken from reference [147]. The line data, bus data and load flow results are given in Tables G.1, and G.2, respectively. The data is on 100 MVA base.

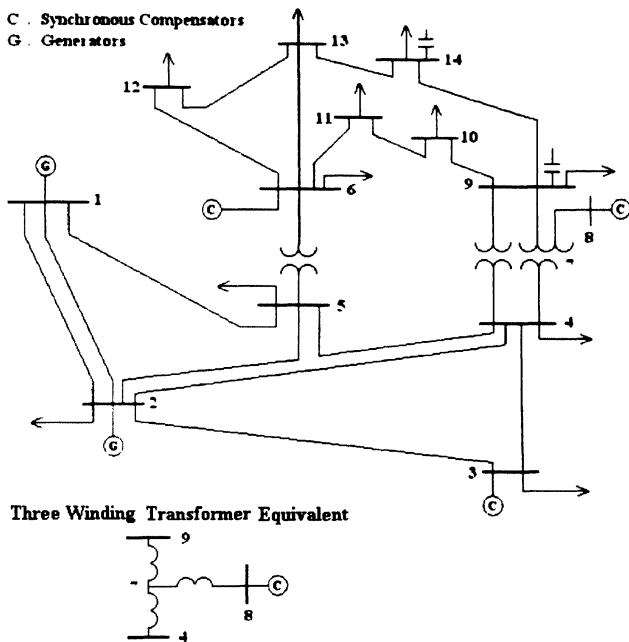

**Table G.1. Line data**

Line No.	From Bus	To Bus	Line Impedance		Half Line Charging Susceptance (p.u.)
			Resistance (p.u)	Reactance (p.u)	
1	1	2	0.01938	0.05917	0.02640
2	2	3	0.04699	0.19797	0.02190
3	2	4	0.05811	0.17632	0.01870
4	1	5	0.05403	0.22304	0.02460
5	2	5	0.05695	0.17388	0.01700
6	3	4	0.06701	0.17103	0.01730
7	4	5	0.01335	0.04211	0.00640
8	5	6	0.00000	0.25202	0
9	4	7	0.00000	0.20912	0
10	7	8	0.00000	0.17615	0
11	4	9	0.00000	0.55618	0
12	7	9	0.00000	0.11001	0
13	9	10	0.03181	0.08450	0
14	6	11	0.09498	0.19890	0
15	6	12	0.12291	0.25581	0
16	6	13	0.06615	0.13027	0
17	9	14	0.12711	0.27038	0
18	10	11	0.08205	0.19207	0
19	12	13	0.22092	0.19988	0
20	13	14	0.17093	0.34802	0

**Table G.2. Bus data and load flow results**

Bus No.	Bus Voltage		Generation		Load		Reactive Power Limits	
	Magnitude (p.u)	Phase angle (degrees)	Real Power (p.u)	Reactive Power (p.u)	Real Power (p.u)	Reactive Power (p.u)	$Q_{min}$ (p.u)	$Q_{max}$ (p.u)
1	1.060	0.000	2.324	-0.169	0.000	0.000	-	-
2	1.045	0.000	0.400	0.000	0.217	0.127	-0.40	0.50
3	1.010	0.000	0.000	0.000	0.942	0.191	0	0.40
4	1.000	0.000	0.000	0.000	0.478	0.039	-	-
5	1.000	0.000	0.000	0.000	0.076	0.016	-	-
6	1.070	0.000	0.000	0.000	0.112	0.075	-0.06	0.24
7	1.000	0.000	0.000	0.000	0.000	0.000	-	-
8	1.090	0.000	0.000	0.000	0.000	0.000	-0.06	0.24
9	1.000	0.000	0.000	0.000	0.295	0.166	-	-
10	1.000	0.000	0.000	0.000	0.090	0.058	-	-
11	1.000	0.000	0.000	0.000	0.035	0.018	-	-
12	1.000	0.000	0.000	0.000	0.061	0.016	-	-
13	1.000	0.000	0.000	0.000	0.135	0.058	-	-
14	1.000	0.000	0.000	0.000	0.149	0.050	-	-

**Table G.3. Transformer tap setting data**

<b>From Bus</b>	<b>To Bus</b>	<b>Tap Setting Value (p.u.)</b>
4	7	0.978
4	9	0.969
5	6	0.932

**Table G.4. Shunt capacitor data**

<b>Bus No.</b>	<b>Susceptance (p.u.)</b>
9	0.19

## APPENDIX – H

### DATA FOR AN IEEE-57 BUS TEST SYSTEM

The System data is taken from reference [147]. The line data, bus data and load flow results for an IEEE-57 bus system given in Tables H.1 and H.2, respectively. The transformer tap setting and shunt capacitor data are provided in Table H.3 and H.4, respectively. The data is on 100 MVA base.

**Table H.1. Line data**

Line No.	From Bus	To Bus	Line Impedance		Half Line Charging Susceptance (p.u)
			Resistance (p.u)	Reactance (p.u)	
1	1	2	0.0083	0.028	0.0645
2	2	3	0.0298	0.085	0.0409
3	3	4	0.0112	0.0366	0.0190
4	4	5	0.0625	0.132	0.0129
5	4	6	0.043	0.148	0.0174
6	6	7	0.02	0.102	0.0138
7	6	8	0.0339	0.173	0.0235
8	8	9	0.0099	0.0505	0.0274
9	9	10	0.0369	0.1679	0.0220
10	9	11	0.0258	0.0848	0.0109
11	9	12	0.0648	0.295	0.0386
12	9	13	0.0481	0.158	0.0203
13	13	14	0.0132	0.0434	0.0055
14	13	15	0.0269	0.0869	0.0115
15	1	15	0.0178	0.091	0.0494
16	1	16	0.0454	0.206	0.0273
17	1	17	0.0238	0.108	0.0143
18	3	15	0.0162	0.053	0.0272



19	4	18	0	0.555	0
20	4	18	0	0.43	0
21	5	6	0.0302	0.0641	0.0062
22	7	8	0.0139	0.0712	0.0097
23	10	12	0.0277	0.1262	0.0164
24	11	13	0.0223	0.0732	0.0094
25	12	13	0.0178	0.058	0.0302
26	12	16	0.018	0.0813	0.0108
27	12	17	0.0397	0.179	0.0238
28	14	15	0.0171	0.0547	0.0074
29	18	19	0.461	0.685	0
30	19	20	0.283	0.434	0
31	21	20	0	0.7767	0
32	21	22	0.0736	0.117	0
33	22	23	0.0099	0.0152	0
34	23	24	0.166	0.256	0.0042
35	24	25	0	1.182	0
36	24	25	0	1.23	0
37	24	26	0	0.0473	0
38	26	27	0.165	0.254	0
39	27	28	0.0618	0.0954	0
40	28	29	0.0418	0.0587	0
41	7	29	0	0.0648	0
42	25	30	0.135	0.202	0
43	30	31	0.326	0.497	0
44	31	32	0.507	0.755	0
45	32	33	0.0392	0.036	0
46	34	32	0	0.953	0
47	34	35	0.052	0.078	0.0016

48	35	36	0.043	0.0537	0.0008
49	36	37	0.029	0.0366	0
50	37	38	0.0651	0.1009	0.0010
51	37	39	0.0239	0.0379	0
52	36	40	0.03	0.0466	0
53	22	38	0.0192	0.0295	0
54	11	41	0	0.749	0
55	41	42	0.207	0.352	0
56	41	43	0	0.412	0
57	38	44	0.0289	0.0585	0.0010
58	15	45	0	0.1042	0
59	14	46	0	0.0735	0
60	46	47	0.023	0.068	0.0016
61	47	48	0.0182	0.0233	0
62	48	49	0.0834	0.129	0.0024
63	49	50	0.0801	0.128	0
64	50	51	0.1386	0.22	0
65	10	51	0	0.0712	0
66	13	49	0	0.191	0
67	29	52	0.1442	0.187	0
68	52	53	0.0762	0.0984	0
69	53	54	0.1878	0.232	0
70	54	55	0.1732	0.2265	0
71	11	43	0	0.153	0
72	44	45	0.0624	0.1242	0.0020
73	40	56	0	1.195	0
74	56	41	0.553	0.549	0
75	56	42	0.2125	0.354	0
76	39	57	0	1.355	0

77	57	56	0.174	0.26	0
78	38	49	0.115	0.177	0.0030
79	38	48	0.0312	0.0482	0
80	9	55	0	0.1205	0

Table H.2. Bus data and load flow results

Bus No.	Bus Voltage		Generation		Load		Reactive Power Limits	
	Magnitude (p.u)	Phase Angle (degrees)	Real Power (p.u)	Reactive Power (p.u)	Real Power (p.u)	Reactive Power (p.u)	$Q_{\min}$ (p.u)	$Q_{\max}$ (p.u)
1	1.040	0.000	4.78	1.289	0.55	0.17	-	-
2	1.010	0.000	0.000	-0.008	0.03	0.88	-0.17	0.50
3	0.985	0.000	0.4	-0.01	0.41	0.21	-0.10	0.60
4	1.000	0.000	0.000	0.000	0.000	0.000	-	-
5	1.000	0.000	0.000	0.000	0.13	0.04	-	-
6	0.98	0.000	0.000	0.008	0.75	0.02	-0.08	0.25
7	1.000	0.000	0.000	0.000	0.000	0.000	-	-
8	1.005	0.000	4.50	0.621	1.50	0.22	-1.40	2
9	0.98	0.000	0.000	0.022	1.21	0.26	-0.03	0.09
10	1.000	0.000	0.000	0.000	0.05	0.02	-	-
11	1.000	0.000	0.000	0.000	0.000	0.000	-	-
12	1.015	0.000	3.10	1.285	3.77	0.24	-0.5	1.55
13	1.000	0.000	0.000	0.000	0.18	0.023	-	-
14	1.000	0.000	0.000	0.000	0.105	0.053	-	-



38	1.000	0.000	0.000	0.000	0.14	0.07	-	-
39	1.000	0.000	0.000	0.000	0.000	0.000	-	-
40	1.000	0.000	0.000	0.000	0.000	0.000	-	-
41	1.000	0.000	0.000	0.000	0.063	0.03	-	-
42	1.000	0.000	0.000	0.000	0.071	0.044	-	-
43	1.000	0.000	0.000	0.000	0.02	0.01	-	-
44	1.000	0.000	0.000	0.000	0.12	0.018	-	-
45	1.000	0.000	0.000	0.000	0.000	0.000	-	-
46	1.000	0.000	0.000	0.000	0.000	0.000	-	-
47	1.000	0.000	0.000	0.000	0.297	0.116	-	-
48	1.000	0.000	0.000	0.000	0.000	0.000	-	-
49	1.000	0.000	0.000	0.000	0.18	0.085	-	-
50	1.000	0.000	0.000	0.000	0.21	0.105	-	-
51	1.000	0.000	0.000	0.000	0.18	0.053	-	-
52	1.000	0.000	0.000	0.000	0.049	0.022	-	-
53	1.000	0.000	0.000	0.000	0.20	0.10	-	-
54	1.000	0.000	0.000	0.000	0.041	0.014	-	-
55	1.000	0.000	0.000	0.000	0.068	0.034	-	-
56	1.000	0.000	0.000	0.000	0.076	0.022	-	-
57	1.000	0.000	0.000	0.000	0.067	0.02	-	-

**Table H.3. Transformer tap setting data**

<b>From Bus</b>	<b>To Bus</b>	<b>Tap Setting Value (p.u.)</b>
4	18	0.97
4	18	0.978
21	20	1.043
24	26	1.043
7	29	0.967
34	32	0.975
11	41	0.955
15	45	0.955
14	46	0.9
10	51	0.93
13	49	0.895
11	43	0.958
40	56	0.958
39	57	0.98
9	55	0.94
24	24	1.000
24	25	1.000

**Table H.4. Shunt capacitor data**

<b>Bus No.</b>	<b>Susceptance (p.u.)</b>
18	0.10
25	0.059
53	0.063

## APPENDIX - I

## DATA FOR INDIAN UTILITY-NTPS-23 BUS SYSTEM

The Indian utility Neyveli Thermal Power Station (NTPS)-23 bus test system is shown in Figure J.1. The sites of buses, line data, bus data, are given in Tables I.1, I.2 and I.3, respectively. A 100 MVA, 400 KV base is chosen.

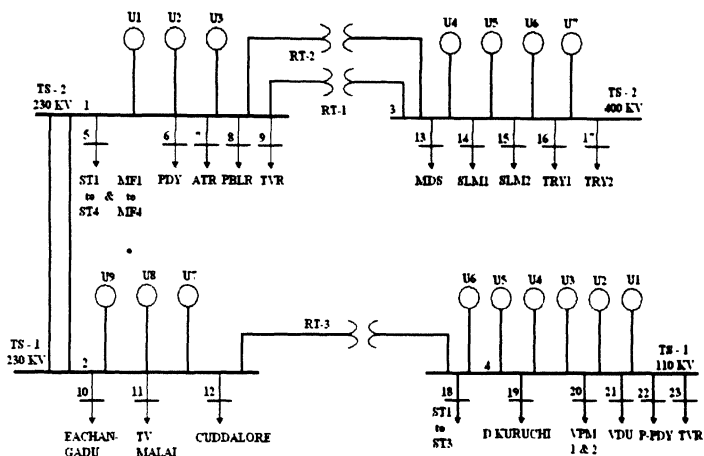

Fig. I.1. One line diagram

**Table I.1. Sites and location of different buses**

<b>Bus No.</b>	<b>Area Code</b>	<b>Locations</b>
1	TS-2 (230 KV)	Thermal Station – 2 230KV
2	TS-1 (230 KV)	Thermal Station – 1 230KV
3	TS-2 (400 KV)	Thermal Station – 2 400KV
4	TS-1 (110 KV)	Thermal Station – 1 110KV
5	ST1-ST4 & MF1 – MF4 (230 KV)	Station Auxillaries
6	PDY (230 KV)	Pondy
7	ATR (230 KV)	Attur
8	PBLR (230 KV)	Perambalur
9	TVR (230 KV)	Thiruvarur
10	EACHANGADU (230 KV)	Eachangadu
11	TV MALAI (230 KV)	Thiruvannamalai
12	CUDDALORE (230 KV)	Cuddalore
13	MDS (400 KV)	Madras
14	SLM1 (400 KV)	Salem1
15	SLM2 (400 KV)	Salem2
16	TRY1 (400 KV)	Trichy1
17	TRY2 (400 KV)	Trichy2
18	ST1 – ST3 (110 KV)	Station Auxillaries
19	D.KURUCHI (110 KV)	Deva Kuruchi
20	VPM 1 & 2 (110 KV)	Villupuram
21	VDU (110 KV)	Vadakuthu
22	P-PDY (110 KV)	Pondicherry
23	TVR (110 KV)	Thiruvarur



**Table 1.2. Line data**

Line No.	From Bus	Between buses	Line impedance	
			Resistance (p.u.)	Reactance (p.u.)
1	1	5	0.0012	0.0061
2	1	6	0.0098	0.0501
3	1	7	0.0138	0.0711
4	1	8	0.0125	0.0642
5	1	9	0.0178	0.0916
6	1	2	0.0013	0.0065
7	2	10	0.0061	0.0312
8	2	11	0.0122	0.0626
9	2	12	0.0049	0.0251
10	2	4	0.0040	0.0810
11	3	1	0.0020	0.0490
12	3	13	0.0019	0.0194
13	3	14	0.0022	0.0226
14	3	15	0.0022	0.0226
15	3	16	0.0016	0.0168
16	3	17	0.0016	0.0168
17	4	18	0.0052	0.0267
18	4	19	0.0522	0.2682
19	4	20	0.0142	0.0727
20	4	21	0.0138	0.0710
21	4	22	0.0153	0.0787
22	4	23	0.0246	0.1266

Table I.3. Bus data

Bus No.	Bus Voltage		Generation		Load		Reactive Power Limits	
	Magnitude (p.u.)	Phase Angle (degrees)	Real Power (p.u.)	Reactive Power (p.u.)	Real Power (p.u.)	Reactive Power (p.u.)	$Q_{min}$ (p.u.)	$Q_{max}$ (p.u.)
1	1.06	0.00	0.00	0.00	0.00	0.00	-	-
2	1.045	0.00	3	0.00	0.00	0.00	-0.37	1.85
3	1.000	0.00	8.4	0.00	0.00	0.00	-1.04	5.20
4	1.060	0.00	3	0.00	0.00	0.00	-0.45	2.25
5	1.010	0.00	0.00	0.00	1.56	0.75	-0.15	0.625
6	1.000	0.00	0.00	0.00	1.27	0.61	-	-
7	1.000	0.00	0.00	0.00	0.56	0.35	-	-
8	1.010	0.00	0.00	0.00	0.70	0.43	-	-
9	1.000	0.00	0.00	0.00	0.93	0.58	-	-
10	1.000	0.00	0.00	0.00	0.57	0.43	-	-
11	1.082	0.00	0.00	0.00	0.68	0.52	-	-
12	1.000	0.00	0.00	0.00	0.72	0.54	-	-
13	1.071	0.00	0.00	0.00	0.35	0.17	-	-
14	1.000	0.00	0.00	0.00	0.69	0.33	-	-
15	1.000	0.00	0.00	0.00	0.78	0.38	-	-
16	1.000	0.00	0.00	0.00	1.64	0.8	-	-
17	1.000	0.00	0.00	0.00	1.64	0.8	-	-
18	1.000	0.00	0.00	0.00	0.76	0.37	-	-
19	1.000	0.00	0.00	0.00	0.64	0.397	-	-
20	1.000	0.00	0.00	0.00	0.29	0.18	-	-
21	1.000	0.00	0.00	0.00	0.32	0.20	-	-
22	1.000	0.00	0.00	0.00	0.23	0.11	-	-
23	1.000	0.00	0.00	0.00	0.23	0.14	-	-

## APPENDIX – J

## DATA FOR INDIAN UTILITY-PUDUCHERRY- 17 BUS SYSTEM

The Indian utility–Pondicherry-17 bus test system is shown in Fig. J.1. The line data, bus data, are given in Tables J.1.and J.2., respectively. A 100 MVA, 110 KV base is chosen.

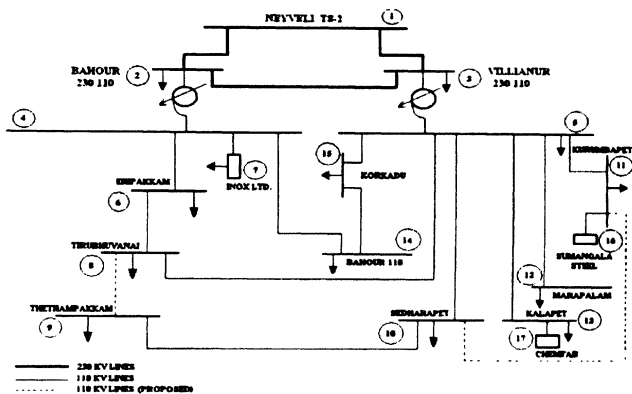

Fig. J.1. One line diagram

Table J.1. Line Data

Line No.	From Bus	To Bus	Line Impedance		Half Line Charging Susceptance (p.u)
			Resistance (p.u)	Reactance (p.u)	
1	1	2	0.00836	0.043065	0.04004
2	1	3	0.0096113	0.049511	0.046033
3	2	3	0.002547	0.0131215	0.012199
4	2	4	0.009634	0	0
5	3	5	0.011814	0	0
6	4	6	0.02193	0.05637	0.0029515
7	4	7	0.001278	0.003285	0.00017

8	4	14	0.00263	0.004491	0.0012
9	5	10	0.03057	0.052365	0.002495
10	5	11	0.00784	0.0294	0.001055
11	5	12	0.011209	0.0192	0.000907
12	5	13	0.04268	0.073122	0.003456
13	5	8	0.01744	0.044823	0.002347
14	5	15	0.015276	0.021252	0.00099
15	6	8	0.008464	0.021757	0.0011392
16	8	9	0.008946	0.02299	0.001204
17	9	10	0.012733	0.03273	0.001714
18	10	11	0.01278	0.03285	0.001720
19	11	16	0.003057	0.005236	0.000248
20	13	17	0.00401	0.006877	0.000325
21	15	14	0.02545	0.03542	0.00185

Table J.2. Bus data

Bus No.	Bus Voltage (p.u.)		Load	
	Magnitude (p.u.)	Phase Angle (degrees)	Real Power (p.u.)	Reactive Power (p.u.)
1	1.01	0.000	0	0
2	1.00	0.000	0.0489	0.01641
3	1.00	0.000	0.0781	0.0449
4	1.00	0.000	0	0
5	1.00	0.000	0.00852	0.00349
6	1.00	0.000	0.04667	0.01622
7	1.00	0.000	0.00223	0.00019
8	1.00	0.000	0.03632	0.01759
9	1.00	0.000	0.01761	0.00853
10	1.00	0.000	0.01982	0.00589

11	1.00	0.000	0.02973	0.01709
12	1.00	0.000	0.03802	0.02002
13	1.00	0.000	0.01861	0.00257
14	1.00	0.000	0.0321	0.01555
15	1.00	0.000	0.00461	0.0005
16	1.00	0.000	0.012	0.023
17	1.00	0.000	0.015	0.01