



A discrete event simulation method for performance analysis of an additive manufacturing in the dental clinic

Amir Hossein Kamali¹ · Mohammad Moradi¹ · Fariba Goodarzian^{1,2} · Peiman Ghasemi³

Received: 10 August 2021 / Accepted: 25 September 2021 / Published online: 7 October 2021
© The Author(s), under exclusive licence to Springer-Verlag London Ltd., part of Springer Nature 2021

Abstract

Three-dimensional printing (3DP) is an evolutionary solution for making customize items for all sectors, but it has become more prominent in the healthcare sector. In this field, some solutions have to be adapted to patients. This is especially true for dentistry, where all the patients have their own unique mouth and tooth structure. It is now possible to provide an accurate model of the patient's mouth and teeth with solutions that are perfectly compatible with them, leading to the provision of a dental service with a high success rate. Even if there is a problem, it is enough to change the three-dimensional design. Therefore, it is a time-saving method, too. The purpose of this study is to investigate the role of 3DP in dentistry and to identify the processes and procedures resulting from the use of this technology. To do so, with the help of a case study, a 3DP-based dental clinic that provides implant, orthodontics, restoration and dentures services is simulated in Arena software. The current state of the system is assessed by defining appropriate evaluation criteria including net profit, utilization, waiting time, patients makespan and laboratory makespan. The simulation model is then developed with innovations such as adding an inventory control policy, creating rest time for resources and controlling the policy of sending products from laboratory to the clinic. After an extensive sensitivity analysis, improving the performance of the system is on the agenda of this paper by examining various scenarios. Results show that scenarios such as reducing some resources of the system or considering rest time in exchange for increasing the duration of the work shift can have a significant impact on clinic performance.

Keywords 3D printing · Additive manufacturing · Healthcare · Dental clinic · Simulation method

1 Introduction

Additive manufacturing (AM), also referred to as Three-dimensional printing (3DP), involves a set of processes in which materials are linked together in a controlled manner to create a three-dimensional object [1]. This is usually done layer by layer based on digital data through computer-aided design software [2].

Although Raymond F. Jones described the general concept of 3D printing in his story "Tools of the Trade" in the 1960s, the first 3DP technology was discovered in 1971 by Johannes F. Gottwald. This technology was called rapid prototyping at the time, because it was actually designed to build the prototype quickly and cheaply for mass production. However, Chuck Hulls' invention of the stereolithographic fabrication system in 1986 was a launching pad for the technology [3–7].

Since then, the unique capabilities of 3DP, including the possibility of making parts with complex geometry, low cost of realization of these complex geometric shapes,

✉ Fariba Goodarzian
fariba.goodarzian@mirlabs.org;
faribagoodarzian7070@gmail.com

Amir Hossein Kamali
ahosseini.kamali@ut.ac.ir

Mohammad Moradi
mhmd.moradi@ut.ac.ir

Peiman Ghasemi
st_p_ghasemi@azad.ac.ir

¹ School of Industrial Engineering, College of Engineering, University of Tehran, Tehran, Iran

² Machine Intelligence Research Labs (MIR Labs), Scientific Network for Innovation and Research Excellence, P.O. Box 2259, 11, 3rd Street NW, WA 98071 Auburn, USA

³ Department of Industrial Engineering, South Tehran Branch, Islamic Azad University, Tehran, Iran

high dimensional accuracy, integrated production of the final product instead of the need to assemble multiple parts and time and cost efficiency in production run has led to a significant growth in the use of this technology in various industries such as aerospace, architecture, automotive, industrial parts, military equipment, medical equipment, art and jewelry [8–10]. According to estimates, the 3DP industry has seen a 27% increase in revenue over the past 29 years [11]. In other words, although the use of this technology had non-commercial aspects in the 1980s, the market value of this industry has gradually increased to \$5.7 billion in 2014 and \$21 billion in 2021 [12]. This growth is expected to continue with a similar slope, reaching \$78 billion in 2028 [13].

3DP will be one of the most effective and essential parts of logistics and supply chain in the near future. An important development that 3D printing creates in traditional supply chains is the conversion of their production system into make-to-order system, which helps eliminate demand uncertainties, and the closer 3D printers are to end customers, the greater the advantage [14]. For example, Amazon, as one of the largest online stores in the world, has installed 3D printers in delivery trucks. Thus customer orders are

printed on the trucks until they reach their destinations [15]. Simultaneously with the change of production policy, it is possible for supply chains to customize products according to customer demand, which means that each customer can request a specific product with the desired features and characteristics [16].

Other changes that 3DP makes to traditional supply chains include reducing all the production steps to design, prototyping, and manufacturing of highly sophisticated products [17], faster on-demand delivery [18], decentralized production strategy [19], fewer logistics services, and cheaper products (For example, reducing transportation and warehousing costs, eliminating probable imports and exports due to the possibility of local production, reducing the need for new equipment, molds, etc.) [20], and increasing sustainability and efficiency of products through minimal use of materials and energy [21, 22]. Those interested in further studying the effects of 3DP on traditional supply chains can refer to Franco et al. [23], Attaran [24] and Durach et al. [25]. Furthermore, Fig. 1, is the output of R Studio as a scientometrics tool and shows the most cited documents in this field which can also be helpful to study. The input data

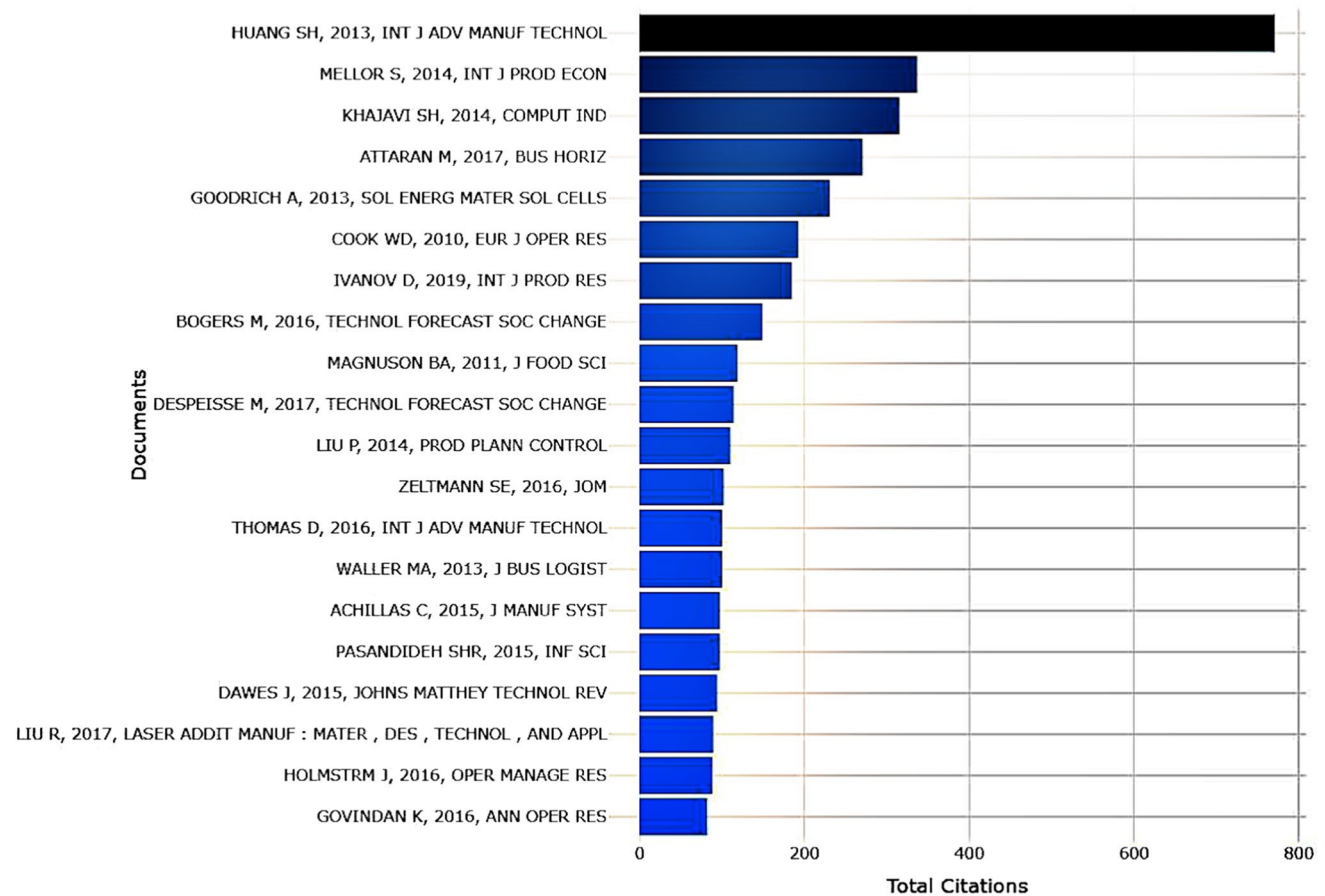

Fig. 1 Most cited documents for "additive manufacturing" plus "supply chain"

to the software is related to studies conducted in the field of “additive manufacturing” plus “supply chain” during the years 2010 to 2020, which were collected from the Web of Science database.

As mentioned before, 3DP transforms and strengthens various industries and supply chains. The health care supply chain is no exception to this rule. There are countless benefits for using 3DP in healthcare, which can improve and save patients' lives. Healthcare applications for 3DP are expanding rapidly, with the industry accounting for \$ 951.2 million of the global 3DP market in 2018. It is projected to be accompanied by a combined annual growth rate (CAGR) of 20.8% by 2026 [26]. One of these applications is the use of 3DP in dental departments. Figure 2 shows a set of applications for this technology in this area.

For example, prosthesis, implants, protective guards, orthodontic brackets, etc. should be molded from the patient's mouth and teeth. This has many disadvantages, such as the errors in molding and ultimately the disproportionate construction of the aforementioned tools. However, there is no need to mold the mouth and teeth by using a 3D printer, and this can significantly reduce possible errors during manufacturing [28–30]. It also takes a lot of time to make a denture or a bridge in the usual way. During this time, the patient will have to wait for them to be ready, and the gap between the teeth will be very annoying. While using 3DP, the dentist must first scan the person's mouth with a device. After that, the bridge or denture is made more quickly and accurately [31, 32]. The process of making and installing dental crowns in restoration also requires at least two visits at intervals of several weeks. This process is reduced to a few days by using crowns made with a 3D printer [33].

As can be seen, the benefits and positive effects of 3DP in dental departments cannot be ignored, and certainly the views on the utilization of this technology in this industry

will continue to grow. This paper models a real case study of a dental clinic in Iran with a discrete event simulation approach. As this dental clinic strives to provide a variety of 3DP-based dental services, analyzing its current status not only helps to provide managers with insights of the clinic's performance, but can also serve as a model for other dental clinics to be in line with the implementation of 3DP technology.

The remainder of this paper is organized as follows: Sect. 3 examines the literature of similar studies. Section 4 first describes the simulation model of proposed 3DP-based dental clinic. Some innovations are then added to the model in order to improve discipline in clinic. After that result analysis, sensitivity analysis, and scenario analysis are presented in Sects. 5, 6 and 7, respectively. Finally, Sect. 8 provides an overview of the steps taken in the study, summarizes the achievements, and gives directions for future research.

2 Literature review

3DP technology with its entry into supply chain management has been recognized as a lever to increase their competitive advantage and efficiency. Therefore, researchers have sought to use it in the best possible way to improve the performance of supply chains. A number of studies have focused on evaluating 3DP in different supply chains and providing conceptual frameworks in this domain. Achilles et al. [34] defined criteria for evaluating traditional production methods and AM. Then they provided a decision-making framework based on multi-criteria decision aid (MCDA) and data envelopment analysis (DEA). This framework helps to determine which production strategies to use in order to have the best efficiency in a “focused” factory. Sun Zhao [35] studied the evolution of the fashion industry with

Fig. 2 Additive manufacturing applications in dentistry [27]

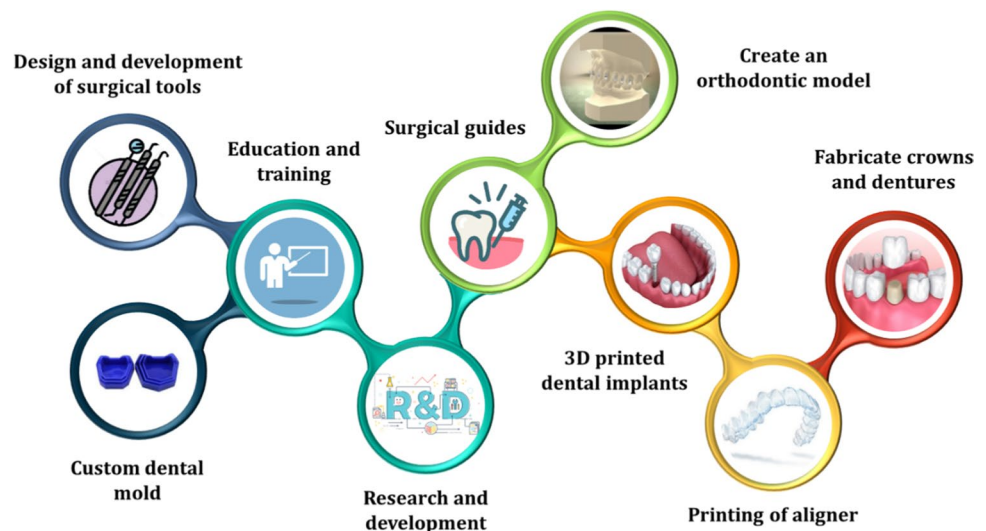

the advent of 3DP and developed a conceptual model for integrating 3DP technology into this industry. Then they identified the challenges and implications of the model in four areas of design and product development, sourcing and manufacturing, retail distribution and consumer, and sustainability optimization. With a quantitative approach, Delic and Eysers [36] collected a questionnaire from 124 small and medium-and large-sized automotive manufacturing companies in the European Union. They evaluated the interaction of AM, supply chain flexibility and supply chain performance, and showed a direct positive impact of AM on automotive industry.

Although conceptual models are abundant in the study of 3DP, some investigations have been done in the field of quantitative and optimization models. For example, about economic objective functions Emelogu et al. [37] proposed a two-stage stochastic programming model that examines the economic feasibility of deploying 3D printers in hospitals and the use of AM for biomedical implants production with respect to supply chain cost analysis. Also about environmental objective functions Tang et al. [38] pointed out to the environmental aspects of AM and argued that since this technology facilitates changes in product design that promotes sustainability, they cannot be assessed by the general life cycle assessment (LCA) tool. Therefore, by adding the product design stage to the LCA tool, they presented a new framework for enhancing the environmental indicators of this technology. Using system dynamics simulations, Li et al. [39] economically and environmentally compared different spare parts supply chain scenarios with and without AM, and quantified the positive effects of 3DP on supply chain performance.

3D printer location-allocation problems are another topics of interest. Emelogu et al. [40] tried to determine the location decisions of AM machines as well as raw material inventory policy for the biomedical implant supply chain through the Continuous Approximation model. Strong et al. [41] proposed a two-stage p-median model that can create a hybrid production system by adding AM machines to traditional production machines at an optimal cost. Further they specified capacity utilization and how demands are assigned to each type of machine. Brito et al. [42] combined p-median, location-allocation and mixed-integer linear programming to design spare parts supply chains for a real-world case study providing elevator maintenance services in Brazil, where spare parts are produced by 3D printers.

Process scheduling on 3D printers and controlling their efficiency have not gone unnoticed. Chergui et al. [43] solved the problem of production scheduling for a number of parallel 3DP machines with the aim of maximizing machine utilization and minimizing order delivery delays in two sub-problems, including job assignment and job scheduling. Yilmaz [44] addressed an optimization model for the

two-stage supply chain problem in order to minimize the makespan. In the first stage, the scheduling and allocation of jobs to the AM machines is determined, and in the second stage, the allocation of vehicles to the machines for the distribution of jobs to customers is specified.

In addition to the physical facilities required for 3DP, such as printers, an important part of this technology is digital data management. Chung et al. [45] considered a smart supply chain with AM capability consisting of smart factories, which can interact with each other instantly through the cloud. They developed two optimization models for dynamic supply chain design and supply chain operations plan to meet the unique demand of customers. By simulating different scenarios, Mashhadi and Monory [46] showed that AM cloud services pricing and optimal matching of 3D printers with buyers, in addition to optimal matching of production orders with manufacturers based on deep learning approach, can increase the utility of this system, and handle high fluctuations of demand through Internet of Things (IoT) technology. 3DP technology also plays a prominent role in the current major challenge in the world, the COVID-19 virus. Manero et al. [47] and Tarfaoui et al. [48] studied the performance of AM in supplying necessary equipment (from personal protective equipment to ventilators) to control the pandemic as well as possible future epidemics and not to face shortages in this area.

Unlike all previous studies, this paper simulates a real case study of a dental clinic that is able to provide various dental services based on 3DP with a discrete event simulation approach. To date, simulation of 3DP-based dental departments has not been considered in the literature, and this research can open a vision to the analysis of this section. It should be noted that this study is close to the study of Ozceylan et al. [49] who investigated the effect of AM on the orthopedic insoles supply chain with a simulation approach. The concept presented in that article, along with new innovations and more details, is examined here to survey the impact of 3DP in the new industry. The main contributions of this paper can be summarized as follows:

- Implementation of the model on a new case study in dental industry
- Providing several different services instead of one service in the dental clinic
- Considering the cost parameters imposed on different parts of the model
- Adding inventory control policy to the laboratory
- Creating rest time for resources as well as 3D printer cleaning time in the form of failure
- Controlling the policy of sending products from laboratory to the clinic
- Examining different scenarios based on the results of sensitivity analysis and innovative ideas while trying to

improve system performance according to the results of scenarios.

3 Model description

As mentioned in previous sections, in this study, the simulation model of 3DP technology in dental industry is examined. To do so, a new case study, modern dental clinic, located in Narmak Street, Tehran, has been selected for collecting data as well as identifying the procedures involved in providing 3DP services in dentistry. In this clinic, four services of implants, orthodontics, restorations and dentures are provided to patients using 3DP technology, each of which has its own procedures. Before entering the simulation model, it is necessary to first introduce the assumptions that are considered in modeling this dental clinic:

- The system is considered continuous, i.e. at the end of the day, the system doesn't reset and the patients' turn remain for the next day.
- Since the simulation period is too long, the distribution of input data during this period is considered constant and unchanged.
- The amount of raw materials needed to print a specific product for each patient is the same for all of them.
- It is assumed that each patient requesting an implant or restoration needs treatment for one of their teeth.
- Due to the long simulation period, time value of money and inflation rate are not taken into account and prices are constant during this period.

In the following, the steps taken for the simulation of this dental clinic in ARENA simulation software are explained in details. Due to the complexity of the simulation model, for better and easier understanding, the whole procedures are divided into three parts: clinic-related procedures before 3DP, laboratory-related procedures, and clinic-related procedures after 3DP where each is discussed separately.

3.1 Clinic-related procedures before 3DP

These processes begin when patients enter the clinic. Patients are created by Create module using $39.5 + 21 * BETA(1.14, 1.15)$ distribution. In order to achieve the time between arrivals distribution, collecting data related to the clinic's past performance, reviewing the times of given appointments, and also attending the clinic and observing patients' arrival times, obtain a set of numbers. Entering this data in Arena Input Analyzer tool results in the above distribution for time between arrivals.

An assign module is then used to assign two attributes, arrival time and patient type. The current simulation time, TNOW, is chosen for the arrival time which is used to calculate the makespan of each patient type from the time of entering the clinic to the moment of discharge, in results analysis section. In addition, patients are divided into 20% implant patients, 20% orthodontics patients, 40% restorative patients, and 20% dentures patients, and the values 1 to 4 are assigned to them, respectively. It should be noted that the percentage of different patients can be easily estimated by examining the data related to current and past appointments. After that, each patient is admitted by an admission worker with a time of UNIF (10,15) minutes. N-way by condition Decide module guides each patient to the appropriate path. For each of the outbound paths, an Assign module is used to rename the entity to the type of service required, so that there is no confusion at the end of the simulation to analyze the reports. Figure 3 shows the steps mentioned above.

Now the continuation of each patient's path is described separately. Patients applying for implants are first examined by an implant doctor in UNIF (15,30) minutes. 20% of patients need teeth extraction and 10% of patients need bone graft before implant. Bone grafting is a technique that is required when a patient does not have a sufficient amount of healthy natural bones in his or her mouth that are capable of supporting the dental implants. The rest can enter implant stage without these prerequisites. These three categories are separated by N-way by chance Decide module. It should be

Fig. 3 Clinic-related procedures before 3DP (part 1)

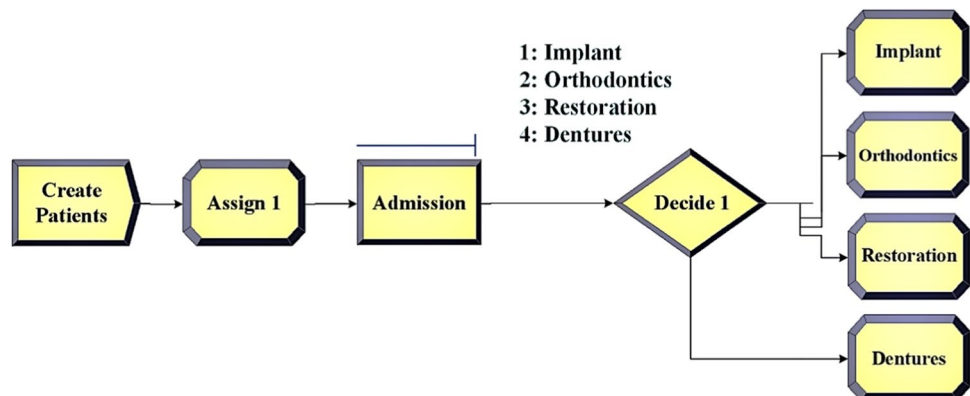

noted that since our main focus is on 3DP technology, we do not consider the details of the teeth extraction and bone grafting processes in the model. The only thing that matters to us is the time required for patients to recover until their next visit. Patients who need teeth extraction should go through this step and return TRIA (14,35,56) days later when they recover which is exerted by Delay module. 20% of patients who have undergone teeth extraction need a bone graft due to gingival resorption, and the rest will enter the implant stage.

All patients who need a bone graft (before and after teeth extraction) return TRIA (90,135,180) days later when they recover which is again exerted by Delay module. Finally, all patients who have met the necessary prerequisites, as well as those who did not need the prerequisites, enter the implant stage. 20% of patients choose immediate implant and 80% of patients choose two-stage implant for their treatment. In the next sections, difference between these two treatments and its effect on the simulation model is clearly stated. Anyway, immediate implant patients are examined by an implant doctor in UNIF (20,30) minutes and pay part of implant cost. This is defined by Assign module with the definition of implant revenue variable as $Implant\ Revenue + Immediate\ Implant\ Price * Pay\ Percent$, where immediate implant price follows a TRIA (240,280,320) dollar distribution. The new attribute of implant type 1 is then assigned to them, which is useful in laboratory-related procedures. Two-stage implant patients are similarly examined in UNIF (20,30) minutes and pay part of the implant cost where Two-Stage Implant Price follows a TRIA (120,160,200) dollar distribution. They then receive the new attributes of implant type 2 and Implant Step 1 through the Assign module. Figure 4 shows the steps mentioned above.

Patients seeking orthodontics are first examined by an orthodontist in UNIF (50,70) minutes. They are reminded

of all the necessary tips and consultations about the orthodontic treatment process during this visit. Then part of the orthodontics cost is paid by the patients, where Orthodontics Price follows a TRIA (600,720,800) dollar distribution. After photographing the patient for UNIF (10,20) minutes, number of aligners required for treatment are determined through TRIA (20,30,50) distribution depending on how irregular the teeth are. Number of referral sessions for checkups, which is based on the number of required aligners, is also obtained. Orthodontics patients should change their aligner every one and a half weeks and have a checkup every UNIF (10,12) weeks. Therefore, number of sessions that each patient visits the clinic during the treatment period is defined by Assign module as $ANINT[(aligner\ number \times 1.5)/11]$, where ANINT means round to the nearest integer and an average of 10–12 weeks is used in the denominator of the fraction.

Patients seeking restoration because of broken teeth are first examined and teeth that need the crown are prepared in TRIA (30,45,60) minutes. For example, dentist may file down and remove part of the outer layer of the teeth. This is done by one of the two existing restoration doctors, who are in the form of a set as a resource. The selection rule is Preferred Order in the sense that priority is to choose the first restoration doctor. Then part of the restoration cost is paid by the patients, where Restoration Price follows a TRIA (30,40,50) dollar distribution.

Patients requesting dentures first undergo pre-dentures procedures by a dentures doctor to make the gums and soft tissues ready for the new teeth in TRIA (40,50,60) minutes. Then part of the dentures cost is paid by the patients, where Dentures Price follows a TRIA (200,220,240) dollar distribution. Patients need UNIF (56,84) days for the gums to heal and get prepared during this time for the installation of dentures. Figure 5 shows the steps mentioned above.

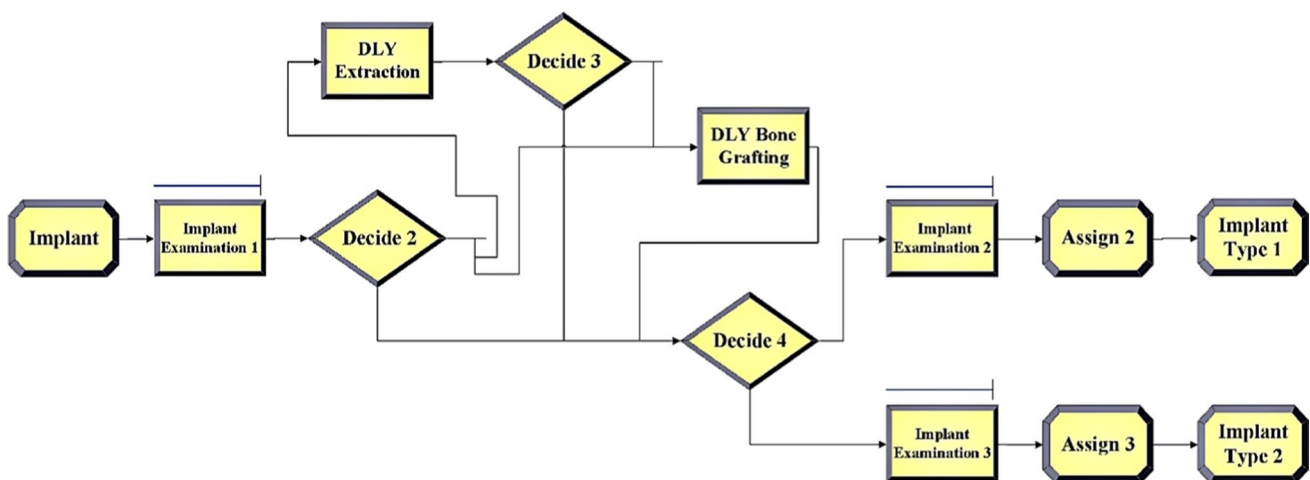

Fig. 4 Clinic-related procedures before 3DP (part 2)

Finally, all patients reach the stage of photography and 3D scanning, which is performed in TRIA (10,12,15) minutes and it is very important to do it carefully because it is the basis of production in laboratory. Then, with the help of the separate module, a copy of patients' files is created and patients go home. Files are stored in Hold module and receive a signal every 4 h. After receiving a signal, they are sent to the laboratory by Route module with a route time of 20 min. Figures 6 and 7 show the steps mentioned above.

All the input data related to this section which are also mentioned in the above description, are summarized in Table 1. Furthermore, an overview of the simulation model

of this section is provided in the supplementary materials (A) due to the limitation of page and readers can see the simulation model seamlessly.

3.2 Laboratory-related procedures

All copies taken from patient' files are entered into this section by Station module and the current simulation time, TNOW, is immediately assigned to the laboratory arrival attribute. This help to calculate the makespan of each patients' files from the time of entering the laboratory to the moment of discharge, in results analysis section. Then,

Fig. 5 Clinic-related procedures before 3DP (part 3)

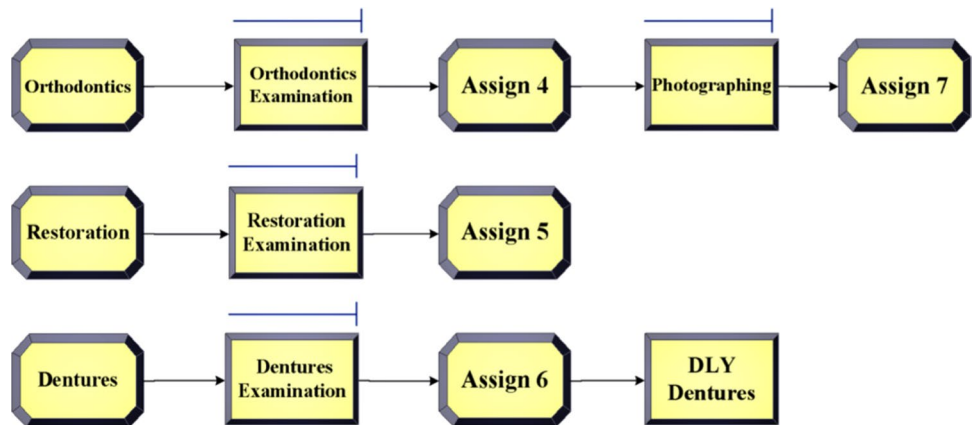

Fig. 6 Clinic-related procedures before 3DP (part 4)

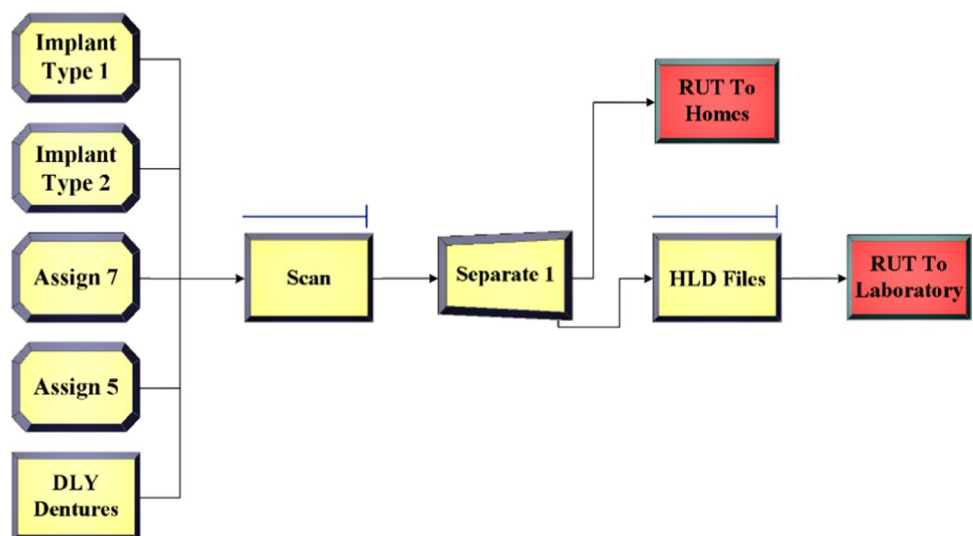

Fig. 7 Clinic-related procedures before 3DP (part 5)

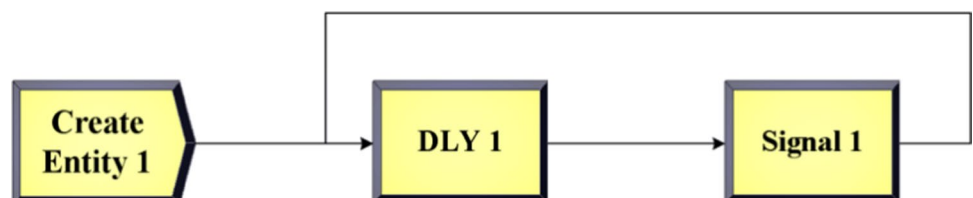

Table 1 Input data of clinic-related procedures before 3DP

Definition	Parameters
Time between arrivals	39.5 + 21*BETA (1.14,1.15) min
Patients admission	UNIF (10,15) min
Implant patients examination	UNIF (15,30) min
Teeth extraction recovery	TRIA (14,35,56) days
Bone graft recovery	TRIA (90,135,180) days
Immediate implant patients examination	UNIF (20,30) min
Immediate implant price	TRIA (240,280,320) dollars
Two-stage implant patients examination	UNIF (20,30) min
Two-stage implant price	TRIA (120,160,200) dollars
Orthodontics patients examination	UNIF (50,70) min
Orthodontics price	TRIA (600,720,800) dollars
Orthodontics photographing	UNIF (10,20) min
Required number of aligners	TRIA (20,30,50)
Required number of referral sessions	ANINT [(aligner number × 1.5)/11]
Restoration patients examination	TRIA (20,30,40) min
Restoration price	TRIA (30,40,50) dollars
Dentures patients examination	TRIA (40,50,60)
Dentures price	TRIA (200,220,240) dollars
pre-dentures recovery	UNIF (56,84) days
photography and 3D scanning	TRIA (10,12,15) min
route time to laboratory	20 min

based on the patient type attribute defined at the beginning of the previous section, patients' files are directed to their own path according to the type of service. Again, how to simulate each path is examined separately.

Files of implant patients are divided into two paths with Decide module based on implant type attribute, and files that are related to two-stage implant are also divided into two parts based on implant step attribute. It is now necessary to clarify the difference between an immediate implant and a two-stage implant. Two main parts of the implant are the fixture and the crown. In an immediate implant, both parts are installed in one session, but in a two-stage implant, the fixture is installed in one session and the crown is installed in another session after a specified period of time. More details about this time interval and installation steps are provided in next section. Although a two-stage implant, is less expensive and has a longer lifespan, but cavities in the mouth between two sessions can be irritating. Therefore, for immediate implant patients' files where demand for fixtures and crowns is clear, both must be printed and prepared at the same time, while in the first step of two-stage implant, only the fixture is printed, and in the second step, only the crown is printed.

In the immediate implant path, since the production of fixtures and crowns has their own steps, so first a copy of patients' files is taken using Separate module. This way, fixtures and crowns production stages can be shown and included in the model, separately. Then it is necessary to

calculate the total cost of raw materials needed to print fixtures and crowns. Titanium powder is used to produce fixtures and resin C&B MFH is used to produce crowns. By defining powder of titanium (resin C&B MFH) total cost variable in Assign module as *powder of titanium (resin C&B MFH) + [powder of titanium (resin C&B MFH) usage* powder of titanium (resin C&B MFH) unit cost]*, total cost of raw materials can be determined. Then temporary Batch modules are added, considering that 3D printer has the ability to print a certain number of fixtures and crowns each time it is used. After that fixtures are printed in UNIF (25,35) minutes and crowns are printed in UNIF (35,45) minutes by 3D printers. Products that are printed require a series of post-production processes to be completed. These processes for printed fixtures include sonication in distilled water and immersion in NaOH and hydrogen peroxide for 35 min and further sonication in distilled water and acid-etched in a mixture of oxalic acid and malic acid for 45 min by ultrasonic cleaner, respectively. These processes help to remove any residual nonadherent titanium particle. Fixtures are then split from existing batch by Separate module and each is polished for 3 min by a polisher. On the other hand, printed crowns undergo post-production processes including IPA (Isopropyl Alcohol) 99% brush for UNIF (3,5) minutes per batch member, air dry for 30 min, and two post-curing in a row with total time of 40 min. Crowns are then split from existing batch and each is polished for 3 min by a polisher. Finally, using Match module, each fixture is matched with a

crowns and is ready to be sent. Above steps are similar for the production of fixtures in the first step of two-stage implant and for the production of crowns in the second step of two-stage implant. Figure 8 shows the steps mentioned above.

For orthodontics patients’ files, total cost of raw materials needed to print aligners are calculated first. Grey resin is used to produce aligners and by defining the total cost of gray resin variable in Assign module, total cost of its consumption is determined. Since each patient has their own number of aligners, it takes $TRIA$ (Aligner number*2, Aligner number*2.5, Aligner number*3) minutes for printing their required aligners. After printing aligners, post-production processes, including IPA (Isopropyl Alcohol) 96% brush for 0.5 min per aligner, ultra-sonication for 10 min, air dry for 5 min, post-curing for 30 min, and thermoforming for 45 min lead to the completion of all aligners for each patient.

For restoration patients’ files, since it is necessary to produce a crown again, all the steps of simulating crown production processes mentioned for the implant are repeated here.

For dentures patients’ files, it should be noted that dentures consist of two parts, the base and the teeth, each of which is printed and produced separately and then combined to each other. Therefore, similar to the immediate implant, a copy of patients’ files is first taken with Select module so that the production stages of each can be shown and included in the model. Then total cost of raw materials needed to print dentures base and teeth must be calculated. Dentures base LP resin is used to produce dentures base and Dentures teeth A2 resin is used to produce dentures teeth. By defining the total cost of Dentures base LP resin variable and Dentures teeth A2 resin variable in Assign module, total cost of their consumption are considered in the model. The important point here is that each denture includes two bases and two sets of teeth for the upper and lower jaws. Therefore, if the printer is capable of producing 8 bases and 8 series of teeth

at the same time, batch size should be considered equal to 4 because 4 dentures are actually produced. On the other hand, it is necessary to pay attention to the consumption rate of raw materials as well. Dentures base LP resin usage and Dentures teeth A2 resin usage should reflect the amount of resin for the production of two bases and two series of teeth. The bases are printed by the printer in UNIF (110,130) minutes and the teeth in UNIF (80,100) minutes. Then they are taken out of the batch and after the base and teeth are combined together by Match module, it is the turn of post-production processes. UV curing for UNIF (5,10) minutes, Post-curing for 15 min, and polishing for 3 min, lead to the completion of dentures. All products are placed in the Hold module and after receiving the daily signal, they are sent to the clinic by the Route module within 30 min. Figures 9, 10 and 11 show the steps mentioned above.

All the input data related to this section which are also mentioned in the above description, are summarized in Table 2. Furthermore, an overview of the simulation model of this section is provided in the supplementary materials (B) due to the limitation of page and readers can see the simulation model seamlessly.

3.3 Clinic-related procedures after 3DP

The continuation of the steps that take place in clinic after 3DP of products is now being examined. Upon receipt of products, the serial number of the product is placed in the customer number variable by Assign Module. Then, by Search and Remove module, the condition of equalization of patients’ serial number who are waiting in the HLD for Call Queue with customer number is searched. If this condition is met, the patient leaves the queue and it takes $TRIA$ (40,50,70) minutes to reach the clinic and match with corresponding product. Then each patient is directed to the

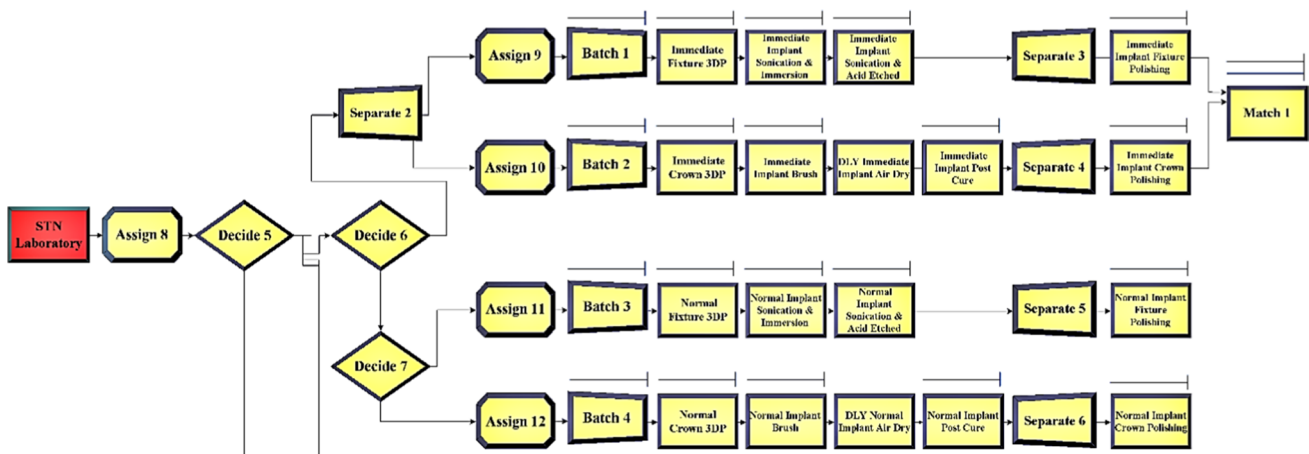

Fig. 8 Laboratory-related procedures (part 1)

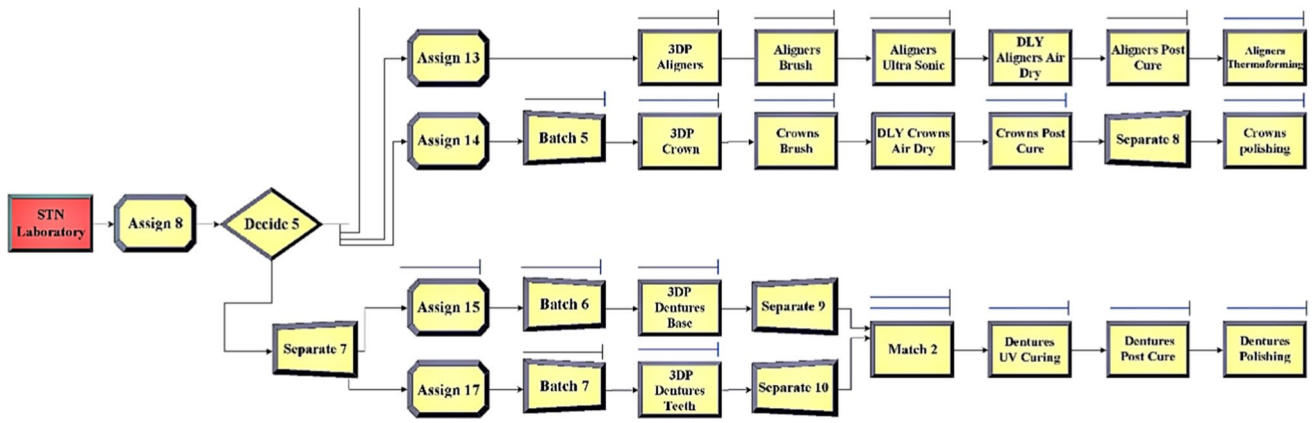

Fig. 9 Laboratory-related procedures (part 2)

Fig. 10 Laboratory-related procedures (part 3)

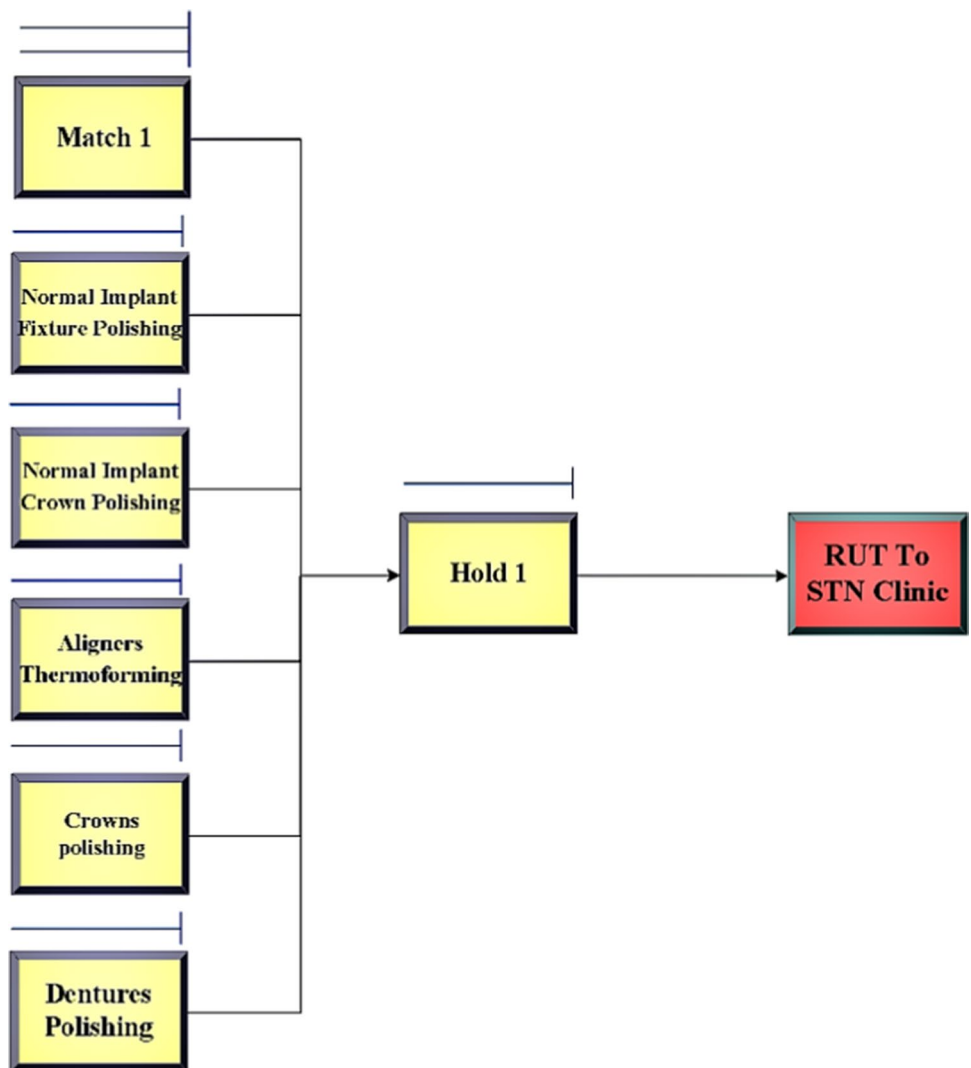

Fig. 11 Laboratory-related procedures (part 4)

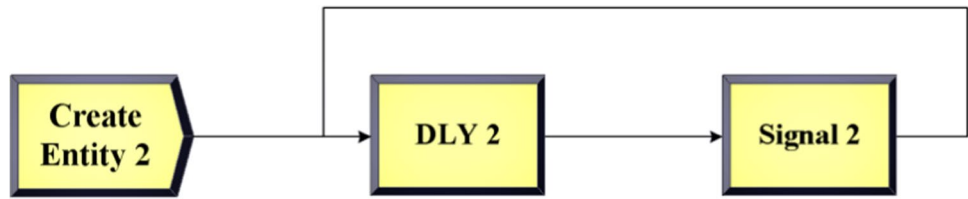

Table 2 Input data of laboratory-related procedures

Definition	Parameters
Fixture batch size in immediate implant	5
Fixture batch size in two-stage implant	10
Fixture printing	UNIF (10,15) min
Fixture sonication and immersion	35 min
Fixture sonication and acid-etched	45 min
Fixture polishing	3 min
powder of titanium usage	2 gr
Crown batch size in immediate implant	5
Crown batch size in two-stage implant	10
Crown printing	UNIF (35,45) min
Crown IPA brushing	Batch size × UNIF (3,5) min
Crown drying in the air	30 min
Crown post-curing	40 min
Crown polishing	3 min
C&B MFH resin usage in implant	15 gr
Aligner printing	Aligner number × TRIA (2,2.5,3) min
Aligner IPA brushing	Aligner number × 0.5 min
Aligner ultra-sonication	10 min
Aligner drying in the air	5 min
Aligner post-curing	30 min
Aligner thermoforming	45 min
Gray resin usage	70 gr
Crown batch size in restoration	16
C&B MFH resin usage in restoration	30 gr
Dentures base batch size	4
Dentures base printing	UNIF (110,130) min
Dentures base LP resin usage	200 gr
Dentures teeth batch size	4
Dentures teeth printing	UNIF (80,100) min
Dentures teeth A2 resin usage	140 gr
Dentures UV curing	UNIF (5,10) min
Dentures Post-curing	15 min
Dentures polishing	3 min

appropriate path according to the patient type. Figure 12 shows the steps mentioned above.

Implants for immediate implant patients are fully installed by the implant doctor within UNIF (1,3) hour. The important point is that not only for this module but for all the Process modules in this section, the priority is set to high, so that new patients who enter the clinic are treated first. treat new patients who enter the clinic. The rest of the implant cost is

then received by definition of implant revenue variable as $Implant\ Revenue + Immediate\ Implant\ Price \times (1 - Pay\ Percent)$ in Assign module. Record Module records the number of immediate implant patients as well as makespan of each patient from the time of entering the clinic to the moment of discharge.

Patients who have a two-stage implant, in the first step have a fixture installed by implant doctor within UNIF (1,2)

Fig. 12 Clinic-related procedures after 3DP (part 1)

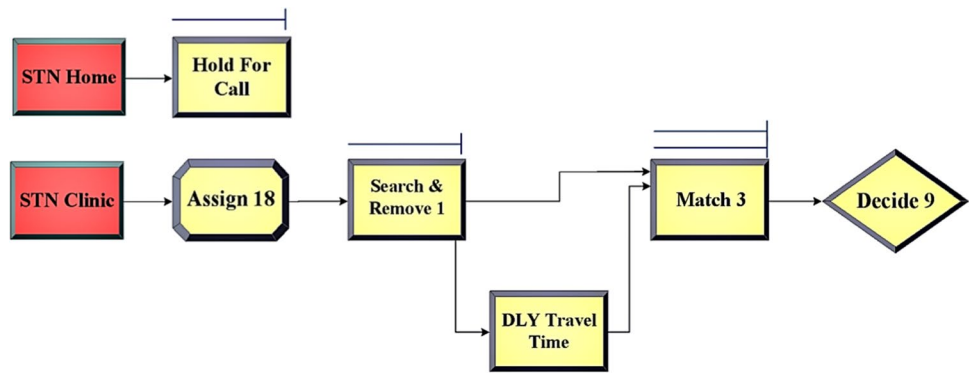

hour. They return to the clinic UNIF (10,15) days later and the sutures are removed within UNIF (10,20) minutes. Then, with a time of TRIA (5,7,10) minutes, a 3D scan is taken and their corresponding step is changed to step two by Assign module. Again similar to clinic-related processes before laboratory, a copy of the patients' file is created and patients go home except that patients should be given UNIF (90,180) days to recover their jawbone. Files are stored in Hold module and sent to the laboratory every 4 h after receiving the signal. It is clear that the files sent from here, in the continuation of their path, enter step two of two-stage implant in the laboratory. Patients who have a two-stage implant, in the second step have a crown installed by implant doctor within UNIF (40,80) minutes and pay the rest of the implant cost. Finally, number of two-stage implant patients as well as makespan of each patient from the time of entering the clinic to the moment of discharge, are recorded. Figure 13 shows the steps mentioned above.

Orthodontic patients, as mentioned, come for checkups periodically, depending on the number of aligners needed during treatment. Therefore, each time they visit the clinic, a unit is added to the number of referral sessions by Assign module as $meeting + 1$. They then examined by an orthodontist for UNIF (30,40) minutes. Decide module is used to check whether the required number of referral sessions

has been completed or not. If it is not over yet, the patient will return UNIF (70,84) days later. If the number of referral sessions is over, the treatment period is ended.

Restoration patients after referral, have their teeth restored within TRIA (40,50,60) minutes by the same restoration doctor who first examined them. This is done by determining a Specific Member as the Selection Rule and RD_ID as the Set Index in the Resources part of the Process module. Finally, they pay the rest of the restoration cost and number of restoration patients as well as makespan of each patient from the time of entering the clinic to the moment of discharge, are recorded.

Dentures for patients are also installed by a denture doctor within TRIA (30,45,60) minutes after their visit. They pay the rest of the dentures cost and number of dentures patients as well as makespan of each patient from the time of entering the clinic to the moment of discharge, are recorded. Figure 14 shows the steps mentioned above.

All the input data related to this section which are also mentioned in the above description, are summarized in Table 3. Furthermore, an overview of the simulation model of this section is provided in the supplementary materials (C) due to the limitation of page and readers can see the simulation model seamlessly.

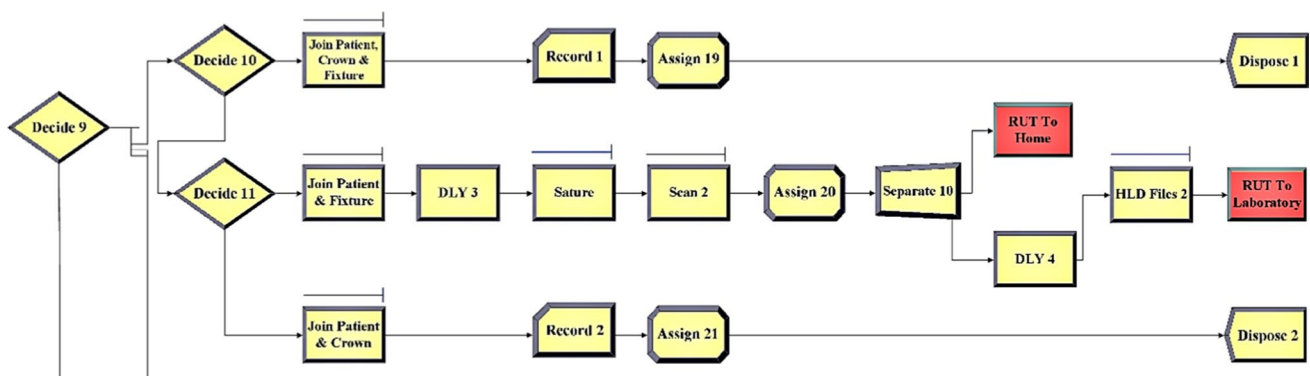

Fig. 13 Clinic-related procedures after 3DP (part 2)

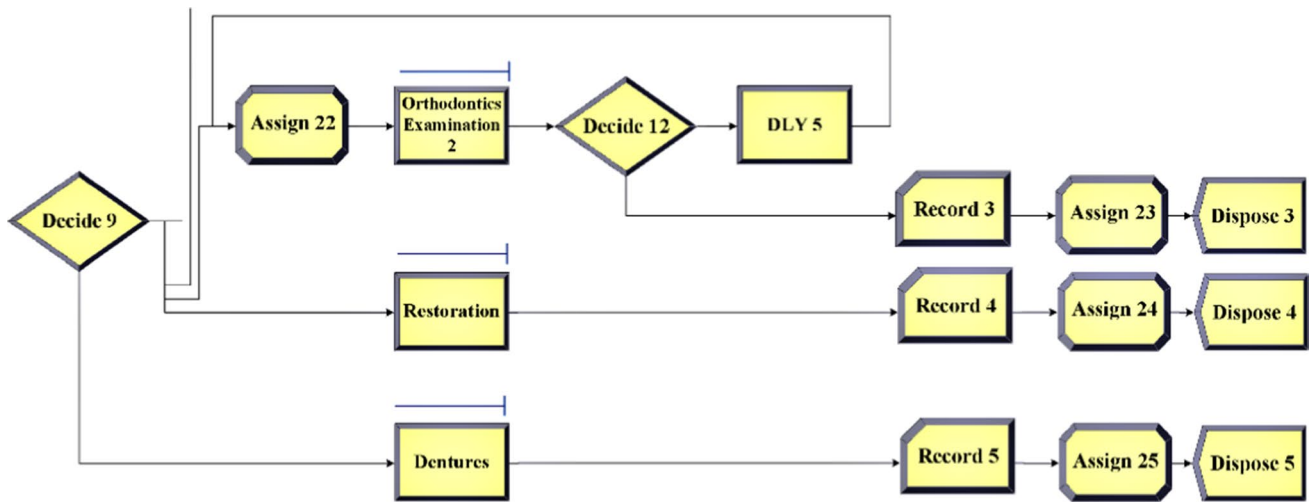

Fig. 14 Clinic-related procedures after 3DP (part 3)

Table 3 Input data of clinic-related procedures after 3DP

Definition	Parameters
Patients travel time to clinic	TRIA (40,50,70) min
Immediate implant installation	UNIF (1,3) hour
Fixture installation in two-stage implant	UNIF (1,2) hour
Recovery time to remove Sutures	UNIF (10,15) days
Sutures removing in two-stage implant	UNIF (10,20) min
Photography and 3D scanning	TRIA (5,7,10) min
Jawbone recovery in two-stage implant	UNIF (90,180) days
Crown installation in two-stage implant	UNIF (40,80) min
Orthodontics checkup time	UNIF (30,40) min
Orthodontics checkup time interval	UNIF (70,84) days
Teeth restoration	TRIA (40,50,60) min
Dentures installation	TRIA (30,45,60) min

Finally, all the resources in the model, which are also mentioned in the descriptions of above sections, and their related input data are summarized in Table 4. It should be noted that the costs incurred for the equipment are related to their operator and not the equipment.

3.4 More innovations and contributions

In previous sections, a number of targeted innovations and contributions were discussed, including implementation of the model on a new case study in dental industry, providing several different services instead of one service in the dental clinic, and considering the cost parameters imposed on different parts of the model. This section tries to add remaining innovations in order to further develop the model and make possible improvements. It should be noted that the effects

Table 4 Resources of the simulation model

Resource	Capacity	Busy/hour	Idle/hour	Per use
Admission worker	1	1	1	0
Examination doctor	1	1.5	1.5	0.25
Implant doctor	1	3	3	0.75
Orthodontist	1	3	3	0.75
Restoration doctor 1	1	2	2	0.5
Restoration doctor 2	1	2	2	0.5
Denture doctor	1	2.5	2.5	0.75
Camera	1	0.5	0.5	0
Scanner	1	1	1	0
3D printer	2	1	1	0
Brush	1	0.5	0.5	0
Ultra sonic cleaner	1	0.5	0.5	0
Post-curing machine	1	0.5	0.5	0
Polisher	1	0.5	0.5	0
Thermoforming machine	1	0.5	0.5	0
UV machine	1	0.5	0.5	0

of all innovations on system performance will be analyzed later in the results analysis section.

3.4.1 Inventory control policy

Since 3DP technology itself has significant efficiency and effectiveness and the procedures for producing products and treating patients are fixed and clear, changing them requires study, review and opinions of decision makers and dental experts. Therefore, we must focus on other parts of the model for improvement and development. One of these parts is the inventory control policy of raw materials used in laboratory for printing products.

In the current model, due to the availability of raw materials in market and ease of supply, there is no specific inventory control policy. However, by designing an appropriate policy, laboratory orders and purchases can be regulated and inventory control costs can be reduced. For this purpose, the inventory control policy (r, Q) is chosen, so that whenever the inventory level becomes less than or equal to the re-ordering point r , an order with a size of Q is issued. In the following, steps of modeling this innovation in Arena simulation software and adding it to the simulation model of previous sections, which is the basis for adding all the innovations, are described in details.

Because the inventory control policy only affects the modeling of laboratory-related procedures part, simulation model of the other two parts, namely clinic-related procedures before laboratory and clinic-related procedures after laboratory, does not change and is the same as before. In the laboratory-related procedures simulation model, as before, all the copies taken from patients' files are entered, the current simulation time is assigned to them, and according to the type of service required, they are directed to one of the paths of implant, restoration, orthodontics and dentures. Then, implant patients' files are divided into two categories: immediate implant and two-stage implant. Finally, two-stage implant patients' files are divided into two categories, first step and second step. Necessary changes are now being examined for one of these paths, and the same is true for other paths.

For example, consider the immediate implant path. In this case, as mentioned, it is necessary to print both the fixture and the crown. Therefore, another copy of the patient's file is taken. One of the changes in the model occurs at this point where two new Decide modules and Hold modules are added to each of the fixture and crown production paths. In the path of producing fixtures, for each file that arrives, the condition

of adequacy of powder of titanium inventory level to produce the fixture is checked by Decide module as $powder\ of\ titanium\ Inv. \geq powder\ of\ titanium\ usage$. If the condition is met, powder of titanium inventory level variable and powder of titanium total usage variable are updated in the form of $powder\ of\ titanium\ Inv. - powder\ of\ titanium\ usage$ and $powder\ total\ usage + powder\ of\ titanium\ usage$, respectively by Assign module. Then the production processes continue from the Batch module, similar to the previous section. But if the condition is not met, files are entered into the Hold module. Type of this module is Scan for Condition, so it constantly monitors a condition similar to the one specified in Decide module. As soon as the condition is met, or in other words, the inventory level reaches the amount required to print the fixture, waiting files in this module are released and entered into the abovementioned Assign module and the production process continues. In the same way, the production path of the crown is modified. Figure 15 shows the steps mentioned above.

Also, these changes are applied in the same way for each of the two-stage implant, orthodontics, restoration, and dentures path. However, it should be noted that in each path, the conditions related to the adequacy of the inventory level in Decide and Hold modules, should be written in proportion to the corresponding raw material of the product. Readers who are interested in seeing these changes in other paths should refer to supplementary materials (D) due to the limitation of page.

Parallel to the changes made in laboratory-related procedures, it is necessary to manage the ordering process when the inventory level is not sufficient. For this purpose, only one entity is created first by Create module which will move in a loop. This entity enters the Hold module, which is again Scan for Condition type, and constantly monitors the condition that inventory level is smaller than re-order point as $powder\ of$

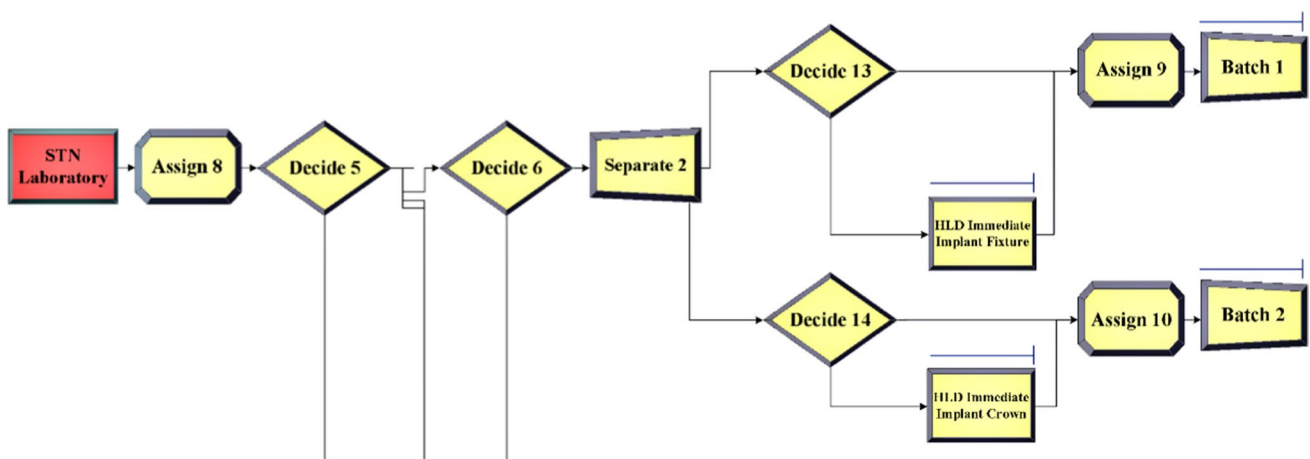

Fig. 15 Laboratory-related procedures with innovation (part 1)

titanium Inv. ≤ *powder of titanium r.* When the condition is met, an order for purchasing titanium powder must be issued. To do this, a Process module with a delay logic and time of one hour is used, which means that one hour after the order is issued, titanium powder reaches the laboratory. Then in the Record module, one unit is added to the number of order. Also, the variables of powder of titanium total cost, powder of titanium inventory level, and total fixed ordering cost are updated in the form of *powder of titanium total Cost + (powder of titanium unit cost × powder of titanium Q)*, *powder of titanium Inv. + Powder of titanium Q*, and *total fixed order cost + fixed order cost*, respectively by Assign module. This loop is repeated consecutively during the simulation period. Figure 16 shows the steps mentioned above.

Similarly, for other raw materials, including resin C&B MFH, gray resin, denture base LP resin and denture teeth A2 resin, ordering policy is determined and is depicted in supplementary materials (E) due to the limitation of page.

3.4.2 Failure

Another part of the model that is possible to modify and can be focused on, are system resources. By considering resource failures, model can be brought closer to the existing conditions in reality. One of the main resources of the model are 3D printers. The failure rate of 3D printers is negligible and can be ignored. But the very important point is that because 3D printers are used to produce different products, it is recommended that after each use, the remaining resins be returned to the bottle and 3D printers' tank be washed. Time required for each wash can be added to the model as a 3D printers' failure. Therefore, in failur data module, 3D printers' failure is defined, Count type with a value of one (i.e., washing per use of 3D printer) is selected for it, and a time of UNIF (5,8) minutes is considered for washing. Then in the resource data module, this defined failure is assigned to the 3D printers.

Dentists are also among the essential resources of the model. Their continuous and uninterrupted activity without rest time definitely affects their performance and reduces their efficiency. This problem can be solved by considering the rest time for dentists. To do this, in failure data module, the rest time for dentists is defined as a failure and its type is set as time. To take 5 min of rest for every two hours of work, up time is set to 2 h and Down Time is set to 5 min. Also, uptime in this State only is set to busy, so that the rest time is applied for two hours of being busy. Then in resource data module, this defined failure is assigned to all dentists including examination

doctor, implant doctor, orthodontics doctor, restoration doctors, and dentures doctor. It should be noted that for failure rule, Wait is chosen, which means that when the rest time arrives, if the dentist is serving the patient, he first finishes the service and then goes for rest. Table 5 shows how to define these failures in the software.

3.4.3 Adjustable batch module

Another innovation that can be added to the model is at the end of the laboratory-related procedures. As explained in previous sections, the current procedure is that after production, products are collected in Hold module and sent to the clinic with a daily signal. This may cause the manufactured products to be delivered to the clinic later, resulting in a longer treatment process for patients. To cope with this challenge, hold module can be removed and replaced with adjustable batch module. In this module, there are two exit modes. First with the definition of Optimum Batch Size equal to 10, every 10 products collected are sent to the clinic. Secondly, by defining the signal in signal code part of this module, whenever the signal arrives, products that are waiting in this module will be batched and sent. In other words, if the defined signal is daily, like the model presented here, at the end of the day no finished product in this module will remain in the laboratory. Figures 17 and 18 show the steps mentioned above and the resulting changes in the model.

3.4.4 Transportation cost

In addition, for further development, cost of transporting products from the laboratory to the clinic is added to the model. This is done by adding an assign module after the adjustable batch module. Transportation costs are defined as *Transportation Cost + Fixed Transportation Cost* in this module. Obviously, adding transportation cost to the model reduces net profit. But the interesting point is the relationship between transportation cost and adjustable batch module. As

Table 5 Adding failure to the simulation model

Failure	Type	Up time	Count	Down time	Uptime in this state only
3D printer	Count	–	1	UNIF (5,8) min	–
Dentists	Time	2 h	–	5 min	Busy

Fig. 16 Laboratory-related procedures with innovation (part 2)

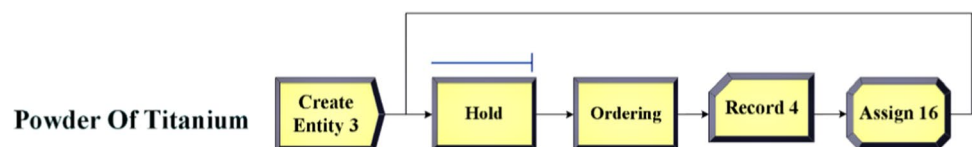

Fig. 17 Laboratory-related procedures with innovation (part 3)

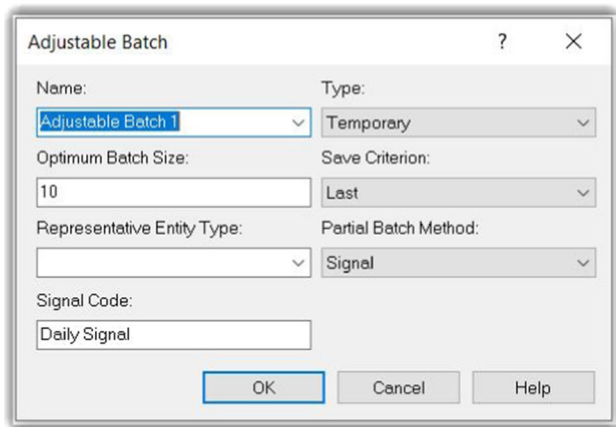
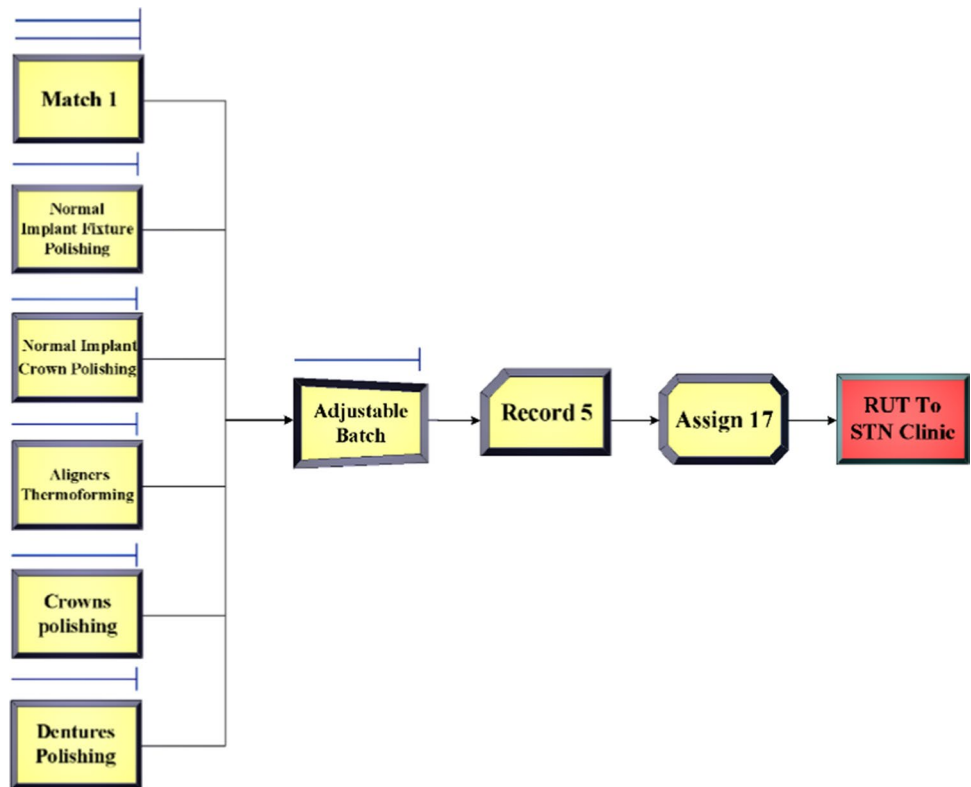

Fig. 18 Adding Adjustable Batch module to the simulation model

increasing the batch size in adjustable batch module leads to a reduction in transportation cost and vice versa. on the other hand, increasing the batch size in adjustable batch module increases the time it takes for the products to reach the clinic as well as the laboratory makespan. Therefore, there is a contradiction in determining batch size.

All values of the new input data as a result of adding the above innovations to the simulation model are summarized in Table 6. Note that holding cost is recognized for holding one unit of raw material in 10 years.

Table 6 Input data of developed simulation model

Definition	Parameters
Resin C&B MFH holding cost	4000
Resin C&B MFH re-ordering point	1
Resin C&B MFH unit cost	480
Resin C&B MFH order quantity	10
Powder of titanium holding cost	8000
Powder of titanium re-ordering point	0.02
Powder of titanium unit cost	60
Powder of titanium order quantity	0.25
Gray resin holding cost	4000
Gray resin re-ordering point	3
Gray resin unit cost	200
Gray resin order quantity	400
Dentures base LP resin holding cost	4000
Dentures base LP resin re-ordering point	1
Dentures base LP resin unit cost	360
Dentures base LP resin order quantity	35
Dentures teeth A2 resin holding cost	4000
Dentures teeth A2 resin re-ordering point	0.6
Dentures teeth A2 resin unit cost	440
Dentures teeth A2 resin order quantity	25
Fixed order cost	4000
Fixed transportation cost	2

3.5 Objective functions and evaluation criteria

In order to be able to assess the status of a system, identify and address its weaknesses, it is first necessary to determine the expectations of the system and to form a framework of objectives and evaluation criteria based on those expectations. With this view, this section introduces the objective functions and evaluation criteria selected, which are the basis of results analysis and sensitivity analysis sections:

3.5.1 Net profit

The main priority of dental clinic is to maximize the net profit that is obtained by deducting total cost from total revenue. Total clinic revenue is the sum of amounts received by providing implant, orthodontics, restoration, and dentures services. Total clinic cost also consists of five parts: total doctors cost, total equipment cost, total ordering cost, total holding cost, and total transportation cost. Total doctors cost and total equipment cost related to the amounts paid for their per use, busy hours, and idle hours. As mentioned before, equipment cost is actually the cost of their operators, not the equipment itself. Total ordering cost is the sum of fixed ordering cost and purchasing cost for all of the raw materials. Total holding cost is the sum of raw materials holding costs, which is obtained by multiplying the average inventory level during the simulation period by the unit holding cost for each of them. Finally, total transportation cost is related to the cost of transporting products from laboratory to the clinic.

3.5.2 Utilization

Since a large amount of expenses are related to payments to doctors and they receive the same amount for their idle hours as well as busy hours, we prefer their busy hours to be as high as possible, which is equivalent to increasing utilization. Thus, the increase in utility indirectly affects the increase in net profit. This criterion is obtained from the average utility of implant doctor, orthodontist, restoration doctors, and denture doctor. It should be noted that there are five categories of doctors. So the average utility is the sum of utilities divided by five.

3.5.3 Patients makespan

Besides of increasing net profit, it should be noted that dental clinic is a service department and deals with patients' health. Therefore, patient satisfaction is also important. One of the effective criteria in patients' satisfaction is their makespan, which is for each patient from the time of entering the clinic to the moment of discharge. The lower the criterion will be; the faster patients will receive the service they need.

3.5.4 Laboratory makespan

Since products needed for providing services to patients are printed in the laboratory, so the laboratory can be considered as one of the main components of the simulation model. Therefore, in analyzing the results of the simulation model, it is necessary to observe the laboratory status separately. If the orders that come to the laboratory are produced and sent to the clinic faster, in addition to reducing the congestion of the laboratory, the efficiency of the whole system will increase. Because the clinic no longer has to wait a considerable amount of time for the products to arrive and can complete the service to the patient faster. Total time from the moment of entering the patients' files to the moment of sending the printed products for all patients makes the evaluation criterion called laboratory makespan.

3.5.5 Waiting time

Another significant evaluation criterion is how long patients or their orders wait in queues. Sum of these times except for the HLD for Call module queue time, gives the waiting time of all patients. HLD for Call module queue time is the amount of time that patients wait for the required product to be printed and called to the clinic, while this time is set aside once for their orders in laboratory queues. Therefore, in order not to be calculated twice, it should not be considered. It is clear that if the waiting time is reduced, patients will be more satisfied because they are waiting less time in the queues, and the overcrowding of the clinic will also be avoided.

4 Results analysis

This section examines the results and outputs of the simulation model using Arena 15.0 simulation package program in the system with the specification of Intel(R) Core(TM) i7-6700HQ CPU and 8.0 GB RAM. Before extracting the outputs, it is necessary to first determine the warm-up period. To do this, the simulation model is first run for a long time and the values of the objective functions are plotted. Since the time it takes for the waiting time to reach equilibrium is longer than the other objective functions and is equivalent to 3 years, this time can be considered as the warm-up period. Then the simulation model is run for 5 replications and each replication for 13 years. Note that the results of the first three years, which is the warm-up period, have no effect on the outputs. Finally, the following outputs are obtained.

4.1 Utilization of resources

Utilization of resources is another result that can be considered. As can be seen in Table 7, the orthodontist and implant doctor have the most utility among the system resources and are busy more than 80% of the time. This is due to the long and complex treatment processes that are required for each patient who needs orthodontics and implants. Other doctors, however, have low utility, so that restoration doctor 2 is only busy 30% of the time, which is almost half the utility of restoration doctor 1. Also, each of the two 3D printers, which is the main resources in the laboratory, is busy 30% of the time. Figure 19 gives a better view of comparing the utilization of resources together.

4.2 Cost of resources

Cost of resources is one of the essential components affecting the system's net profit. Therefore, it is necessary to identify the resources that impose the most cost on the system and reconsider the parts that are under control.

As mentioned, the cost of resources is divided into three categories: cost of busy hours, cost of idle hours and cost per use of each resources. As shown in the previous charts implant doctor and orthodontist are the busiest resources of the system and since their salaries are also significant, they have the highest busy cost in Fig. 20 and have a huge difference with other resources. For similar reasons, usage cost of these two resources is also high as shown in Fig. 21.

Instead, according to Fig. 22, the other three doctors who have longer idle hours and are paid the same as their busy hours, along with 3D printers, have the highest system idle costs. It should be noted that part of the idle hours goes back to the patient arrival rate. Many patients are not aware of 3DP technology in dentistry and its benefits, and those who are aware may have the mentality that the price of these services is very high. In addition to these factors, there are a few number of clinics that use 3DP technology in dentistry. So while the net profit of the clinic is good, it can be greatly improved with policies such as advertising, marketing, and even better pricing.

Table 7 Utilization of resources

Instantaneous utilization	Average	Half width	Minimum average	Maximum average	Minimum value	Maximum value
3D Printer	0.2979	0.00	0.2962	0.2996	0.00	1.0000
Admission worker	0.2501	0.00	0.2499	0.2501	0.00	1.0000
Brush	0.1150	0.00	0.1144	0.1154	0.00	1.0000
Camera	0.0602	0.00	0.0598	0.0608	0.00	1.0000
Denture doctor	0.3372	0.00	0.3334	0.3397	0.00	1.0000
Implant doctor	0.8200	0.01	0.8145	0.8307	0.00	1.0000
Orthodontics doctor	0.8767	0.01	0.8708	0.8851	0.00	1.0000
PC machine	0.2190	0.00	0.2183	0.2203	0.00	1.0000
Polisher	0.6001	0.00	0.0599	0.0603	0.00	1.0000
Restoration doctor 1	0.4864	0.00	0.4818	0.4878	0.00	1.0000
Restoration doctor 2	0.2338	0.00	0.2313	0.2357	0.00	1.0000
Scanner	0.2705	0.00	0.2702	0.2708	0.00	1.0000
Thermoforming machine	0.1803	0.00	0.1792	0.1821	0.00	1.0000
Ultra sonic cleaner	0.0787	0.00	0.0782	0.0793	0.00	1.0000
UV machine	0.0297	0.00	0.0294	0.0299	0.00	1.0000

Fig. 19 Utilization of resources

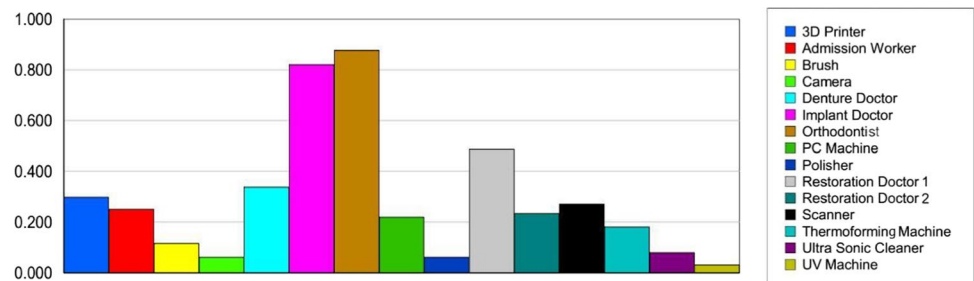

Fig. 20 Busy cost of resources

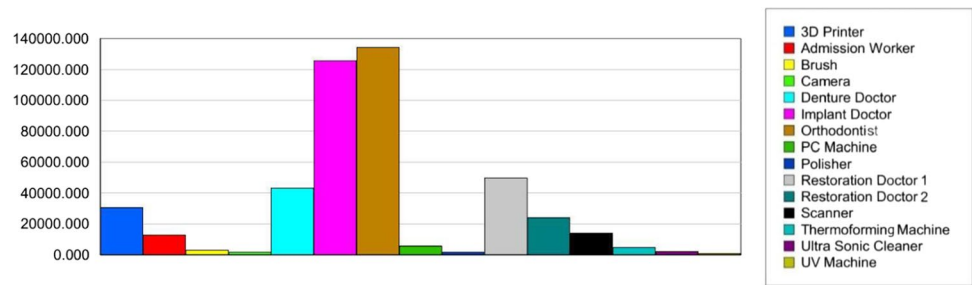

Fig. 21 Usage cost of resources

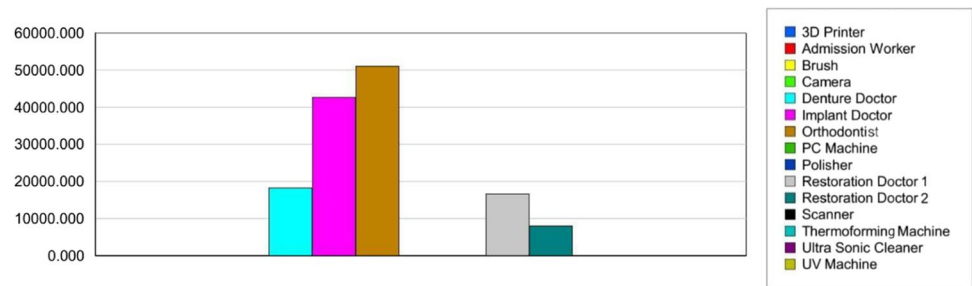

Fig. 22 Idle cost of resources

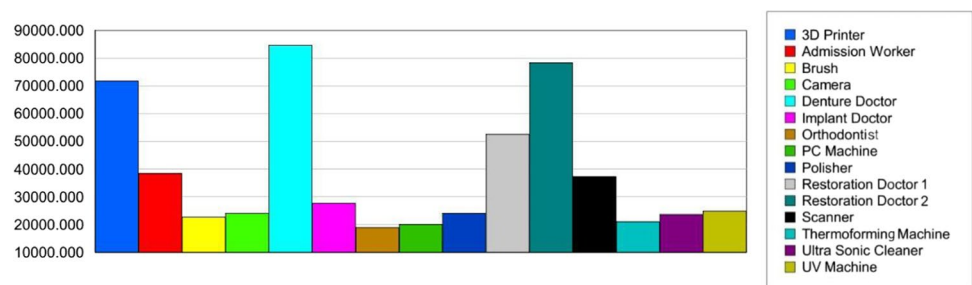

Table 8 Patients and laboratory makespan

Expression	Average	Half width	Minimum average	Maximum average	Minimum value	Maximum value
Denture MS	71.4653	0.06	71.4237	71.5471	56.6277	87.9885
Immediate implant MS	31.1695	0.98	30.0315	31.9574	0.5673	228.27
Two-stage implant MS	180.51	0.77	179.55	181.23	103.59	422.59
Orthodontics MS	274.40	0.34	274.14	274.80	141.62	491.59
Restoration MS	2.0686	0.02	2.0590	2.0926	0.5374	5.3057
Laboratory MS	0.9176	0.01	0.9051	0.9293	0.1443	16.2585
Ultra sonic cleaner	0.0787	0.00	0.0782	0.0793	0.00	1.0000
UV machine	0.0297	0.00	0.0294	0.0299	0.00	1.0000

4.3 Patients and laboratory makespan

Patients makespan is calculated from the moment they enter the clinic until they receive their full service and their treatment at the clinic ends. Laboratory makespan is also calculated from the moment the patients’ files enter the laboratory to the moment when the corresponding

products are printed and sent to the clinic. As shown in Table 8, the average laboratory makespan is approximately 0.9 days, which means that the products are produced and shipped to the clinic in less than one day. As a result, the high makespan of implant, orthodontics and dentures patients is only due to the treatment steps they undergo and has nothing to do with production delays in laboratory.

4.4 Patients waiting time

One of the significant outputs of the simulation model is the waiting time that each type of patient endures until receiving the service. This can help decision makers figure out which type of patients to focus more on and should be revised in term of service procedure to improve their waiting time. According to Table 9, implant patients have the longest waiting time and the main focus should be on this category.

4.5 Raw materials average inventory level

Table 10 shows the average inventory held in the laboratory during the simulation period for each of the raw materials. Based on the information in this table, it is possible to understand the costs of holding inventory. It is clear that the gray resin has a higher average inventory because each patient needs a large number of aligners for treatment. As a result, the highest inventory holding costs are related to gray resin. Also, the average utilization of doctors can be seen in this table, which is the total utilization of implant doctor, two restoration doctors, orthodontist, and dentures doctor divided by five.

5 Sensitivity analysis

This section examines the effect of changes in input data on the values of evaluation criteria. In this way, by identifying the most effective input data, different scenarios can be defined and run based on their changes, and as a result, the values that lead to improved system performance can be obtained.

A very important point is the units of evaluation criteria, which are of different types. This factor makes it impossible to achieve a single understanding of the impact of input data on evaluation criteria. For example, the change in the amount of net profit is based on the currency and the change in the amount of waiting time is based on the unit of time (e.g., day) and these changes are not comparable. Therefore, by normalizing the outputs of the evaluation criteria, all of them can be taken to the same scale (without units) and then their comparison is possible. Normalizing the outputs is also useful for the next section, scenario analysis, because it allows adding the values of different evaluation criteria and by turning the model into a single-objective model, complexities of the multi-objective model are avoided.

To do this, the simulation model is run for 100 replications. The duration of each replication is 13 years and the results of the first three years, which is the warm-up period, have no effect on the outputs. The best values obtained for each of the evaluation criteria are determined from the resulting replications shown in Table 11.

*Net profit is in the scale of 1,000,000 dollars and the unit of patients makespan, laboratory makespan and waiting time is days.

*Best value for net profit and utilization is the maximum amount of outputs and best value for patients makespan, laboratory makespan and waiting time is the minimum amount of outputs.

Finally, by defining expressions (1)–(5) in Statistic module, normalized values of the evaluation criteria are obtained in the outputs:

$$\text{Normalized net profit} = \frac{\text{netprofit statistic}}{3.23089065} \quad (1)$$

Table 9 Patients waiting time

Wait time	Average	Half width	Minimum average	Maximum average	minimum value	Maximum value
Denture patient	3.2102	0.02	3.1869	3.2252	0.5894	41.7365
Implant patient	118.17	0.90	117.60	119.33	0.8640	211.56
Orthodontics patient	3.3863	0.13	3.2644	3.5539	0.5653	34.3401
Restoration patient	3.3077	0.03	3.2860	3.3437	0.5725	37.8117

Table 10 Raw materials average inventory level

Time persistent	Average	Half width	Minimum average	Maximum average	Minimum value	Maximum value
Base resin AVG Inv	18.3584	0.09	18.2492	18.4298	0.0000	35.8000
Denture teeth A2 AVG Inv	13.1076	0.08	13.0137	13.1773	0.0200	25.6000
Grey resin AVG Inv	202.78	1.11	201.94	204.19	0.0308	402.9900
Powder of titanium AVG Inv	0.1457	0.00	0.1450	0.1472	0.0040	0.2700
Resin C & B MFH AVG Inv	5.9730	0.01	5.9646	5.9844	0.8150	11.0000

Table 11 Best values of evaluation criteria

Evaluation criteria	Net profit	Utilization	Patients makespan	Laboratory makespan	Waiting time
Best values in 100 replications	3.23089065	0.55263028	556.84649	0.88951595	106.5962316

$$Normalizedutilization = \frac{doctorsutilization}{0.55263028} \tag{2}$$

$$Normalizedpatientsmakespan = \frac{556.84649}{totalpatientsmakespan} \tag{3}$$

$$Normalizedlaboratorymakespan = \frac{0.88951595}{totallaboratorymakespan} \tag{4}$$

$$Normalizedwaitingtime = \frac{106.5962316}{totalwaitingtime} \tag{5}$$

*Since net profit and utilization objective functions are of the maximization type, the best value is placed in denominator to normalize their outputs.

*Since patients makespan, laboratory makespan and waiting time objective functions are of the minimization type, the best value is placed in numerator to normalize their outputs.

*In general, the closer the normalized value is to one, the more desirable it is.

Because e number of input ta is so large, sensitivity analysis is limited to the most important inputs, namely doctors, 3D printer, and raw materials order quantity. To calculate the sensitivity of each evaluation criterion to each of the input data, nominal, maximum and minimum values of the input data must be available. Nominal values are the same values that the clinic and laboratory currently consider. Also, by reviewing and analyzing the monthly consumption of raw materials, identifying potential amounts for doctors and 3D printer according to the system status and consulting with laboratory and clinic, the maximum and minimum values are obtained.

The nominal values for the input data selected for sensitivity analysis, including doctors, 3D printer, and raw materials order quantity, are given in Table 12.

The input data for the scenarios that must be run to obtain the outputs required for sensitivity analysis are now summarized in Table 13. It should be noted that for each scenario, only the corresponding input data may change by taking its maximum or minimum value however the other input data take their nominal value.

After running the model for 5 replications and each replication for 13 years (first three years are the warm-up period), normalized outputs for the evaluation criteria, corresponding to the input data, can be seen in Table 14.

The sensitivity of each evaluation criterion to each of the input data is now calculated using Eq. (6). An example of this calculation for the implant doctor and net profit evaluation criterion is shown in Eq. (7).

$$Sensitivity = \frac{Output_{max\ input} - Output_{min\ input}}{Output_{nominal\ input}} \tag{6}$$

$$Sensitivity_{\{netprofit|implantdoctor\}} = \frac{0.7839 - 0.9818}{0.9818} = -0.20157 \tag{7}$$

If similar calculations are performed for all evaluation criteria and input data, the results will be obtained according to Table 15.

As can be seen, the negative values of the table indicate the negative effect of the input data on the evaluation criteria. In other words, increasing the input data worsens the evaluation criteria. Conversely, the positive values of the table indicate the positive effect of input data on the evaluation criteria. Based on these positive values, in the last column of the table, number of evaluation criteria that improve with the increase of a particular input data is obtained.

The noteworthy point is the negative effect of all input data on net profit. Of course, for some input data such as implant doctor, orthodontist and restoration doctor 1, this effect is greater, and for some input data such as raw materials, it is negligible. Also, in particular, the increase in gray resin has a negative effect on all evaluation criteria. Another point is the negative effect of increasing the number of each resource (doctors and 3D printer) on utilization, while increasing dentures base LP resin and dentures teeth A2 resin can have little positive effect on it. In other cases, increasing the input data generally has a positive effect on evaluation criteria.

6 Scenario analysis

This section defines different scenarios and examines the outputs of each scenario. This helps to take advantage of one of the best simulation benefits. Thus, the status of the system can be checked under different conditions at the lowest cost and only by running a simulation model. In addition, by observing the results of different scenarios, decision makers can confidently change the status quo to achieve a better situation. An important point here again

Table 12 Nominal values of input data

Input data	Implant doctor	Orthodontist	Restoration doctor 1	Restoration doctor 2	Dentures doctor	3D printer	Dentures base LP resin	Dentures base A2 resin	Dentures teeth	Grey resin	Powder of titanium	Resin C&B MFH
Nominal values	1	1	1	1	1	2	35	25	400	400	0.25	10

Table 13 Input data of sensitivity analysis

Scenario name	Related input	Value
Nominal	–	–
Min implant	Implant doctor	1
Max implant	Implant doctor	2
Min orthodontist	Orthodontist	1
Max orthodontist	Orthodontist	2
Min restoration 1	Restoration doctor 1	1
Max restoration 1	Restoration doctor 1	2
Min restoration 2	Restoration doctor 2	1
Max restoration 2	Restoration doctor 2	2
Min dentures	Dentures doctor	1
Max dentures	Dentures doctor	2
Min 3D	3D printer	1
Max 3D	3D printer	3
Min base resin	Dentures base LP resin	25
Max base resin	Dentures base LP resin	35
Min denture teeth	Dentures teeth A2 resin	15
Max denture teeth	Dentures teeth A2 resin	25
Min grey	Grey resin	300
Max grey	Grey resin	400
Min powder	Powder of titanium	0.2
Max powder	Powder of titanium	0.3
Min C&B	Resin C&B MFH	5
Max C&B	Resin C&B MFH	12.5

is the existence of various evaluation criteria that make it difficult to identify better scenarios. Fortunately, normalization of the values of the evaluation criteria described in the previous section. Therefore, values of the evaluation criteria are all obtained without a unit. Now if we weigh each of the evaluation criteria according to their importance, it is possible to add the resulting values and reach a single number for each scenario, which makes it easier to select the appropriate scenarios.

Consulting with decision makers made it clear that the importance of net profit, utilization, patients makespan, waiting time, and laboratory makespan are 0.4, 0.25, 0.15, 0.15 and 0.05, respectively. It is clear that earning more net profit as the main goal of the clinic gains the most weight. After that, utilization has the highest weight, which can be justified for two reasons. First, high wages of doctors and their equal pay for busy hours and idle hours directly affect net profit. Secondly, because doctors also receive a salary for each patient they visit, they may go to other clinics if they are unemployed. After these two, in order to satisfy the patients as well as to prevent clinic congestion, patients makespan and waiting time are the next priorities. Finally, laboratory makespan has the lowest priority and is important because the products arrive from the laboratory to the clinic earlier and indirectly affect other evaluation criteria.

Table 14 Normalized outputs of sensitivity analysis

Scenario name	Net profit	Utilization	Patients makespan	Laboratory makespan	Waiting time
Nominal	0.9818	0.9967	0.9951	0.9695	0.9894
Min implant	0.9818	0.9967	0.9951	0.9695	0.9894
Max implant	0.7839	0.8469	1.0004	0.9551	1.0079
Min orthodontist	0.9818	0.9967	0.9951	0.9695	0.9894
Max orthodontist	0.7881	0.8371	0.9956	1.0003	0.9961
Min restoration 1	0.9818	0.9967	0.9951	0.9695	0.9894
Max restoration 1	0.8416	0.8872	0.9953	0.9718	0.9908
Min restoration 2	0.9818	0.9967	0.9951	0.9695	0.9894
Max restoration 2	0.8408	0.9520	0.9944	0.9697	0.9893
Min dentures	0.9818	0.9967	0.9951	0.9695	0.9894
Max dentures	0.8077	0.9338	0.9942	0.9757	0.9902
Min 3D	1.0426	0.9968	0.9924	0.8572	0.9793
Max 3D	0.9067	0.9961	0.9951	1.0256	0.9925
Min base resin	0.9841	0.9966	0.9943	0.9676	0.9874
Max base resin	0.9818	0.9967	0.9951	0.9695	0.9894
Min denture teeth	0.9865	0.9966	0.9947	0.9671	0.9884
Max denture teeth	0.9818	0.9967	0.9951	0.9695	0.9894
Min grey	1.0365	0.9967	0.9955	0.9734	0.9913
Max grey	0.9818	0.9967	0.9951	0.9695	0.9894
Min powder	0.9819	0.9967	0.9951	0.9695	0.9894
Max powder	0.9818	0.9967	0.9951	0.9695	0.9894
Min C&B	0.9827	0.9967	0.9951	0.9695	0.9894
Max C&B	0.9819	0.9967	0.9951	0.9695	0.9894

Table 15 Results of sensitivity analysis

Inputs	Net profit	Utilization	Patients makespan	Laboratory makespan	Waiting time	Positive effects
Implant doctor	-0.20157	-0.15029	0.00533	-0.01485	0.01869	2
Orthodontist	-0.19729	-0.16013	0.00050	0.03177	0.00677	3
Restoration doctor 1	-0.13567	-0.10986	0.00020	0.00237	0.00142	3
Restoration doctor 2	-0.14361	-0.04485	-0.00070	0.00021	-0.00010	1
Dentures doctor	-0.17733	-0.06311	-0.00090	0.00639	0.00081	2
3D printer	-0.13842	-0.00070	0.00271	0.17369	0.01334	3
Dentures base LP resin	-0.00234	0.00010	0.00080	0.00196	0.00202	4
Dentures teeth A2 resin	-0.00479	0.00010	0.00040	0.00247	0.00101	4
Grey resin	-0.05571	0	-0.00040	-0.00402	-0.00192	0
Powder of titanium	-0.00010	0	0	0	0	0
Resin C&B MFH	-0.00081	0	0	0	0	0

6.1 Scenario A

These scenarios are defined based on the results of sensitivity analysis section. As can be seen in the last column of Table 16, number of positive effects that a change in the value of a particular input has on the evaluation criteria is determined. Changes in dentures base LP resin and dentures

teeth A2 resin have a positive effect on four evaluation criteria, while their negative effects on net profit is also very small. Therefore, it seems necessary to study the scenarios based on the changes of these two inputs. 3D printer is another suitable input for defining scenarios, considering that it has a positive effect on three evaluation criteria and at the same time has the most positive effect among other

Table 16 Suggested options for raw materials order quantity

Raw materials	Ten-years consumption	Annual consumption	Monthly consumption	Suggested options
Dentures base LP resin	2208.64	220.864	18.40533	(15,20,25)
Dentures teeth A2 resin	3155.2	315.52	26.29333	(25,30,35)

inputs on patients makespan. Also, orthodontist and restoration doctor 1 with three positive effects are other attractive inputs.

Although it may seem easy to determine some values for doctors and 3D printer, it is challenging for raw materials order quantity. Therefore, in order to achieve a set of suggested values for raw materials order quantity, the simulation model is run for 10 years and the amount of raw materials consumed during this period is determined. Then they are converted into monthly consumption of raw materials and the result can be used to obtain the required values as shown in Table 16.

Table 17 lists the selected values for all of the five inputs in various scenarios.

The results of running the simulation model for the above scenarios are noted in Table 18:

All scenarios that have a score higher than the nominal score and are marked in green are better than the current situation, but the scenario that is highlighted and means selecting the lowest values for all inputs is the best for the system among these scenarios.

6.2 Scenario B

The main focus of this scenario is on utilization. One of the ideas that comes to mind to increase utilization is to allocate a considerable amount of rest time to resources and instead increase work shifts. Therefore, in failure data module, the rest time of 30 min for every 6 h of presence in the clinic (busy or idle) is defined in the form of failure according to Table 19.

Then in Resource data module, defined failure is assigned to all resources. Note that for resources such as scanner, this break is for the operator. Finally, work shift is increased from 14 to 15 h in Run Setup. Results of this scenario are summarized in Table 20. Figure 23 also provides a better view of comparing the evaluation criteria of these two scenarios.

As can be seen, this scenario improves net profit, utilization, and laboratory makespan but worsens the patients makespan and waiting time. In general, considering the weight of the evaluation criteria, because it has a score higher than nominal score, it is a good scenario.

Table 17 Selected values for inputs in scenario A

Scenario name	Orthodontist	Restoration doctor 1	3D printer	Dentures base LP resin	Dentures teeth A2 resin
Max OR	2	1	2	35	25
Max res	1	2	2	35	25
Min 3D	1	1	1	35	25
Max 3D	1	1	3	35	25
Min base	1	1	2	25	25
Med base	1	1	2	30	25
Max base	1	1	2	35	25
Min A2	1	1	2	35	15
Med A2	1	1	2	35	25
Max A2	1	1	2	35	30
Min all	1	1	1	25	15
Max all	2	2	3	35	25
Med all	1	1	2	30	20
Max OR/res min 3D/base/A2	2	2	1	25	15
Min base Med A2	1	1	2	25	20
Min A2 Med base	1	1	2	30	15

Table 18 Outputs of scenario A

Scenario name	Net profit	Utilization	Patients makespan	Laboratory makespan	Waiting time	Score
	Weights					
	0.4	0.25	0.15	0.05	0.15	
Nominal	0.9818	0.9967	0.9951	0.9695	0.9894	0.9880
Max OR	0.7881	0.8371	0.9956	1.0003	0.9961	0.8733
Max res	0.8486	0.8872	0.9953	0.9718	0.9908	0.9077
Min 3D	1.0426	0.9968	0.9924	0.8572	0.9793	1.0048
Max 3D	0.9067	0.9961	0.9951	1.0256	0.9925	0.9611
Min base	0.9841	0.9966	0.9943	0.9676	0.9874	0.9884
Med base	0.9813	0.9966	0.9943	0.9676	0.9874	0.9873
Max base	0.9865	0.9967	0.9951	0.9695	0.9894	0.9880
Min A2	0.9818	0.9966	0.9947	0.9671	0.9884	0.9896
Med A2	0.9761	0.9967	0.9951	0.9695	0.9894	0.9880
Max A2	0.9735	0.9966	0.9947	0.9671	0.9884	0.9854
Min all	1.0566	0.9968	0.9924	0.8572	0.9793	1.0104
Max all	0.6052	0.7277	0.9965	1.0221	1.001	0.7747
med all	0.9844	0.9966	0.9943	0.9676	0.9874	0.9885
Max OR/res	0.7375	0.7282	0.9942	0.8677	0.9883	0.8178
Min 3D/base/A2						
Min base	0.9872	0.9966	0.9943	0.9676	0.9874	0.9897
Med A2						
Min A2	0.9884	0.9966	0.9943	0.9676	0.9874	0.9901
Med base						

Table 19 Inputs of scenario B

Failure	Type	Up time	Count	Down time	Uptime in this state only
Rest	Time	6 h	–	30 min	–

6.3 Scenario C

The first scenario was applied to the inputs with the highest number of positive effects. However, considering the results of the sensitivity analysis listed in Table 16, it can be concluded that Restoration doctor 2 has four negative effects on the evaluation criteria, which is the highest number of negative effects among the inputs. Therefore, in this scenario, removal of Restoration doctor 2 from the

resources is examined. By removing this resource, modifications should be made to the simulation model. In Process modules that Restoration doctor 1 and Restoration doctor 2 were assigned as a set, only Restoration doctor 1 is now assigned. In addition, in the Statistic module, parts related to Restoration doctor 2 are deleted so that they are not included in the calculations. Also, utilization of doctors in the new case is obtained from the total utilization divided by 4 because one of the doctors has been removed. Numerical results of this scenario are shown in Table 21. Figure 24 also provides a better view of comparing the evaluation criteria of these two scenarios.

In this scenario, net profit, utilization, and laboratory makespan improves but patients makespan and waiting time worsens. In general, considering the weight of the evaluation criteria, because it has a score higher than nominal score, it is a good scenario.

Table 20 Outputs of scenario B

Scenario name	Net profit	Utilization	Patients makespan	Laboratory makespan	Waiting time	Score
	Weights					
	0.4	0.25	0.15	0.05	0.15	
Nominal	0.9818	0.9967	0.9951	0.9695	0.9894	0.9880
Rest time	1.0716	0.9954	0.9886	0.9854	0.9708	1.0207

Fig. 23 Comparison of evaluation criteria in scenario B

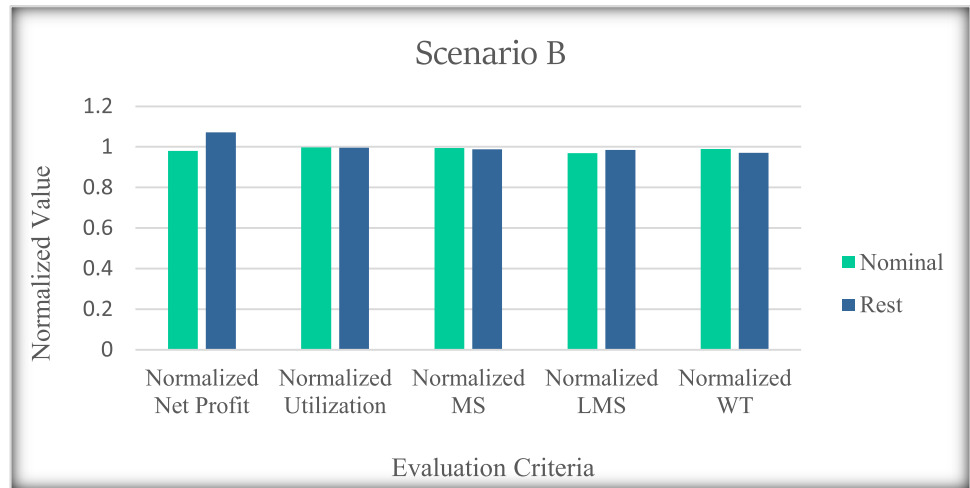
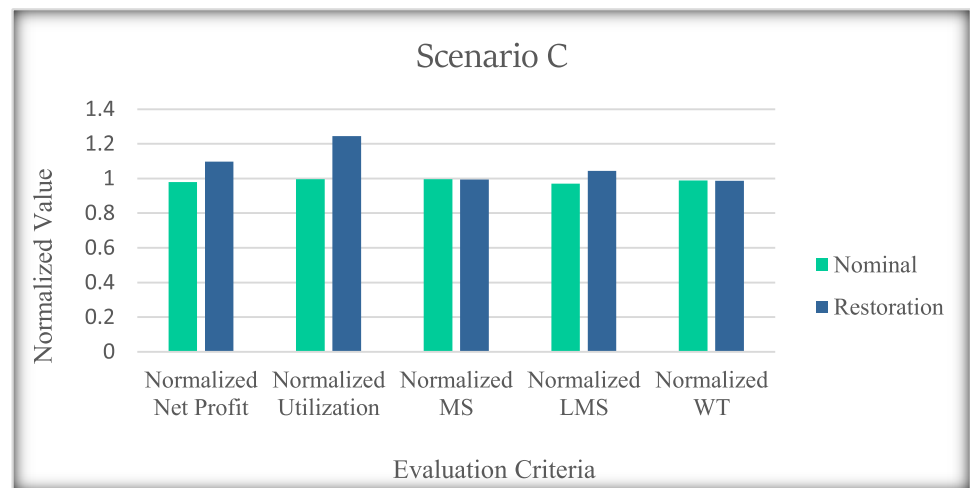

Table 21 Outputs of scenario C

Scenario name	Net profit	Utilization	Patients makespan	Laboratory makespan	Waiting time	Score
	Weights					
	0.4	0.25	0.15	0.05	0.15	
Nominal	0.9818	0.9967	0.9951	0.9695	0.9894	0.9880
Restoration	1.0965	1.2446	0.9933	1.0444	0.9867	1.0990

Fig. 24 Comparison of evaluation criteria in scenario C



6.4 Scenario D

It seems that if the printed products arrive at the clinic sooner, laboratory makespan and waiting time will be reduced, and on the other hand, utilization of doctors will be increased by reducing their idle hours. This scenario examines several different modes for Adjustable Batch module located at the end of the laboratory-related procedures. Signal and batch size are the two main values of this module. Table 22 shows the corresponding numerical

results for different states of these values, including batch size 1 with 10-day signal, batch size 5 with half-day signal and batch size 20 with 2-day signal. Note that batch size 1 is a limit state. In other words, every product that is produced is sent the clinic without actually being batched.

Figure 25 shows the trend of changes in the values of evaluation criteria in different scenarios. As can be seen, the resulting changes in evaluation criteria are irregular and none of the scenarios give a better result than the

Table 22 Outputs of scenario D

Scenario name	Net profit	Utilization	Patients makespan	Laboratory makespan	Waiting time	Score
	Weights					
	0.4	0.25	0.15	0.05	0.15	
Nominal	0.9818	0.9967	0.9951	0.9695	0.9894	0.9880
Adjustable batch 1	0.9263	0.9973	0.9954	0.7316	1.0100	0.9572
Adjustable batch 5	0.9693	0.9954	0.9969	0.9561	1.0038	0.9845
Adjustable batch 20	0.9872	0.9952	0.9905	0.9993	0.9634	0.9867

Fig. 25 Comparison of evaluation criteria in scenario D

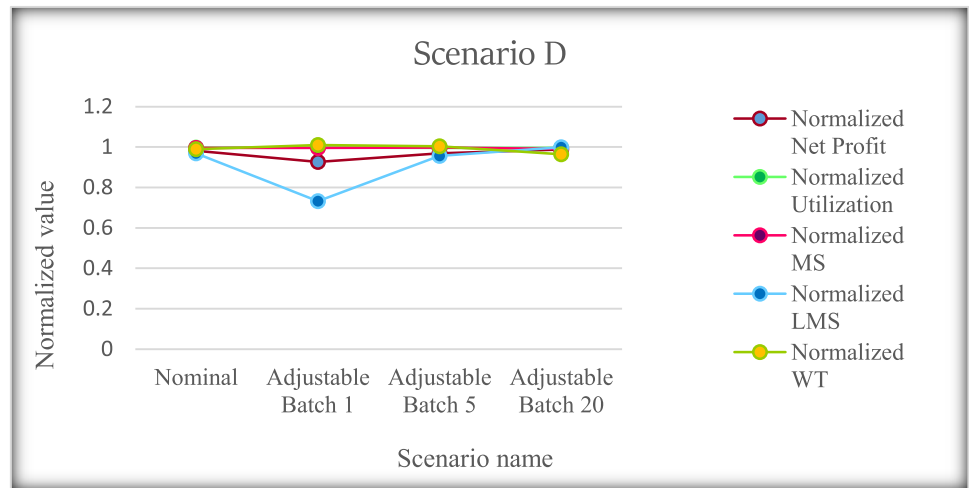

nominal case. However, the Adjustable Batch 20 scenario is the best of the above scenarios.

6.5 Scenario E

Since inventory control policy is one of the key parts of this simulation model, this scenario focuses on the effects of different states of this policy on evaluation criteria. Values of re-ordering point for each of the raw materials in the original model were determined by the laboratory. However, in this scenario, the results are obtained for different values of re-ordering point to see if better values can be found for it. To do this, the amount of monthly consumption of raw materials obtained in Table 17 is used. The re-ordering point is now set at 10, 20 and 50% of monthly consumption for three scenarios. Also, two scenarios are considered for the limit state. For the first limit state, re-ordering point is equal to its lowest possible value, which is the amount of raw materials usage for one patient. These values can be obtained from the input data. Consumption rates of powder of titanium, resin C&B MFH, grey resin, dentures base LP resin, and dentures teeth A2 resin, for one patient are 2, 45, 3500, 200, and 140 g, respectively. It should be noted that the gray resin usage has

been calculated for the worst case of a patient who needs 50 aligners. For the second limit state, re-ordering point takes its maximum possible value, which is the monthly consumption of each raw material. Numerical results of this scenario are shown in Table 23.

Figure 26 shows the trend of changes in the values of evaluation criteria in different scenarios.

As can be seen, the increase in re-ordering point, despite improving the laboratory makespan, severely worsens the net profit and also negatively affects other evaluation criteria. Therefore, the scenario of putting re-ordering point at its lowest value is the best scenario among the above scenarios, which also improves the nominal case.

Finally, to create an overview of the defined scenarios, the best scenario of each of the above sections is selected and Fig. 27 shows the values of the different evaluation criteria derived from them in an integrated chart. Their numerical results are also summarized in Table 24.

Obviously, scenario C has a higher score than other scenarios and its implementation should be a priority. However, if the conditions for its implementation are not provided, decision makers can move on to other scenarios, B, A, E and D, respectively.

Table 23 Outputs of scenario E

Scenario name	Net profit	Utilization	Patients makespan	Laboratory makespan	Waiting time	Score
	Weights					
	0.4	0.25	0.15	0.05	0.15	
Nominal	0.9818	0.9967	0.9951	0.9695	0.9894	0.9880
Material r min	0.9848	0.9965	0.9936	0.9824	0.9888	0.9895
Material r 10%	0.9266	0.9945	0.9933	0.9754	0.9886	0.9653
Material r 20%	0.8823	0.9945	0.9933	0.9754	0.9886	0.9476
Material r 50%	0.7430	0.9945	0.9933	0.9754	0.9886	0.8919
Material r max	0.5142	0.9945	0.9933	0.9754	0.9886	0.8004

Fig. 26 Comparison of evaluation criteria in scenario E

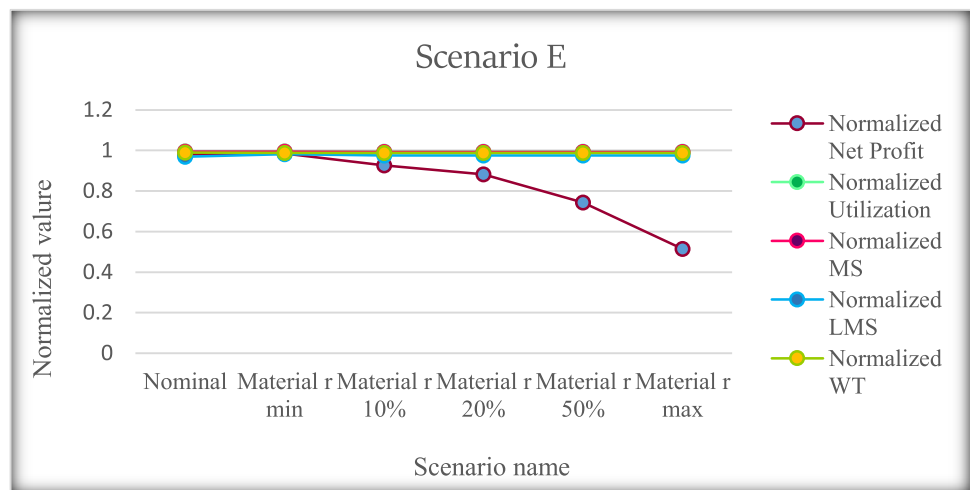
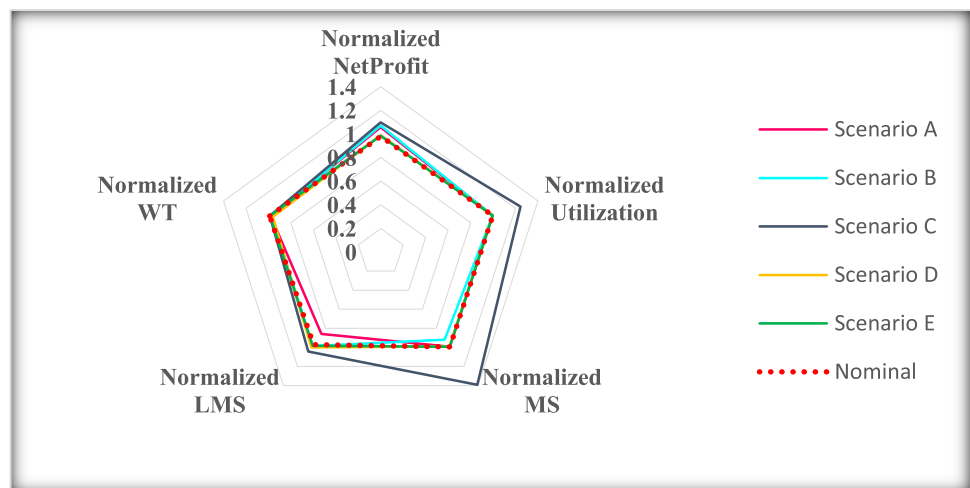

Fig. 27 Comparison of best scenarios



7 Conclusion

3DP technology has been growing rapidly since its inception due to the unique benefits and capabilities it brings. Different industries are moving away from traditional

production methods and turning to this technology to try to improve their processes and outputs and ultimately improve their supply chain performance. One of these industries is healthcare and especially dentistry, in which 3DP technology has the potential to create a huge evolution.

Table 24 Summary of the results of scenarios

Scenario name	Net profit	Utilization	Patients makespan	Laboratory makespan	Waiting time	Score
	Weights					
	0.4	0.25	0.15	0.05	0.15	
Nominal	0.9818	0.9967	0.9951	0.9695	0.9894	0.9880
Scenario A	1.0566	0.9968	0.9924	0.8572	0.9793	1.0104
Scenario B	1.0716	0.9954	0.9886	0.9854	0.9708	1.0207
Scenario C	1.0965	1.2446	0.9933	1.0444	0.9867	1.0990
Scenario D	0.9872	0.9952	0.9905	0.9993	0.9634	0.9867
Scenario E	0.9848	0.9965	0.9936	0.9824	0.9888	0.9895

In this regard, this paper used a real case study to show the applications of 3DP technology in dentistry and to study the procedures that are followed in the presence of this technology to provide services to patients. Simultaneous consideration of different services and the necessary steps to complete and provide each service to patients is one of the remarkable points of this paper. After creating an initial simulation model of this dental clinic, more innovations and contributions were added to the model with the aim of improving system performance and bringing the simulation model closer to the real world. Then, net profit, utilization, patients makespan, laboratory makespan, and waiting time were identified as important and influential evaluation criteria on system performance from the perspective of decision makers. Based on these selected evaluation criteria, a comprehensive sensitivity analysis was performed on the parameters of this system, in which input data related to orthodontist, restoration doctor 1, 3D printer, dentures base LP resin, and dentures teeth A2 resin were determined as the most effective inputs. Finally, to optimize the system performance using the results of sensitivity analysis as well as innovative ideas of the authors, numerous scenarios were created. By analyzing the outputs of the scenarios, the best of each section were selected. Consequently, removing Restoration doctor 2 from the system is the best possible case. After that adding half an hour of rest for every six hours, and instead increase the work shift by one hour, minimizing the amount of effective inputs mentioned above, and minimizing re-ordering points of all the raw materials can be another alternative to improve the performance of the system over the current situation. Decision makers can use these scenarios as a favorable perspective for the dental clinic according to their executive capabilities.

Potential topics for further studies include:

To make the model more realistic, the amount of raw materials used for each patient can be considered different.

To examine the effectiveness of the ordering policy, Other inventory control policies can be applied to the model.

For services such as implant and restoration, patients' demand for different numbers of teeth can be examined. By adding a mathematical model to the laboratory, it is possible to determine the production schedule of different products on 3D printers at the same time.

Multiple-criteria decision-making (MCDM) or other mathematical models such as unified data envelopment analysis (UDEA), can be added to the model and help to evaluate suppliers and select the best ones to supply raw materials.

The probability that a number of patients may return to the clinic sometime after receiving the service, for reasons such as broken crowns or implants, can be considered in the model.

Supplementary Information The online version contains supplementary material available at <https://doi.org/10.1007/s00170-021-08135-7>.

Author contributions AHK: Conceptualization, Data curation, Formal analysis, Methodology, Writing—original draft. MM: Resources. FG: Supervision, Validation, Project administration, Review & editing. PG: Validation, Visualization, Editing.

Declarations

Conflict of interest The authors declare that they have no conflict of interest.

Informed consent Informed consent was not required as no human or animals were involved.

Research involving human and animal rights This article does not contain any studies with human or animal subjects performed by any of the authors.

References

- Gardan J (2016) Additive manufacturing technologies: state of the art and trends. *Int J Prod Res* 54(10):3118–3132. <https://doi.org/10.1080/00207543.2015.1115909>

2. Ransikarbum K, Pitakaso R, Kim N (2020) A decision-support model for additive manufacturing scheduling using an integrative analytic hierarchy process and multi-objective optimization. *Appl Sci* 10(15):5159. <https://doi.org/10.3390/app10155159>
3. Zarringhalam H (2007) Investigation into crystallinity and degree of particle melt in selective laser sintering. Dissertation, Loughborough University
4. Ngo TD, Kashani A, Imbalzano G, Nguyen KT, Hui D (2018) Additive manufacturing (3D printing): a review of materials, methods, applications and challenges. *Compos B Eng* 143:172–196. <https://doi.org/10.1016/j.compositesb.2018.02.012>
5. Chua CK, Leong KF, Lim CS (2010) Rapid prototyping: principles and applications (with companion CD-ROM). World Scientific Publishing Company, Singapore
6. Thompson MK, Moroni G, Vaneker T, Fadel G, Campbell RI, Gibson I, Bernard A, Schulz J, Graf P, Ahuja B (2016) Design for additive manufacturing: trends, opportunities, considerations, and constraints. *CIRP Ann* 65(2):737–760. <https://doi.org/10.1016/j.cirp.2016.05.004>
7. Ian Gibson IG (2015) Additive manufacturing technologies 3D printing, rapid prototyping, and direct digital manufacturing. Springer, New York
8. Gao W, Zhang Y, Ramanujan D, Ramani K, Chen Y, Williams CB, Wang CC, Shin YC, Zhang S, Zavattieri PD (2015) The status, challenges, and future of additive manufacturing in engineering. *Comput Aided Des* 69:65–89. <https://doi.org/10.1016/j.cad.2015.04.001>
9. Hopkinson N, Hague R, Dickens P (2006) Rapid manufacturing: an industrial revolution for the digital age. Wiley, New Jersey
10. Karunakaran K, Bernard A, Suryakumar S, Dembinski L, Tailandier G (2012) Rapid manufacturing of metallic objects. *Rapid Prototyping J* 18(4):264–280. <https://doi.org/10.1108/1355254121231644>
11. Campbell I, Diegel O, Kowen J, Wohlers T (2018) Wohlers report 2018: 3D printing and additive manufacturing state of the industry: annual worldwide progress report. Wohlers Associates, Colorado
12. Holst A (2020) 3D printing market size worldwide from 2013 to 2021. Statista Technology & Telecommunications. <https://www.statista.com/statistics/796237/worldwide-forecast-growth-3d-printing-market/>. Accessed 1 April 2020
13. Wood L (2020) Global additive manufacturing market and technology forecast 2020–2028. Intrado Research and Markets. <https://www.globenewswire.com/news-release/2020/09/15/2093525/0/en/Global-Additive-Manufacturing-Market-and-Technology-Forecast-2020-2028.html>. Accessed 15 September 2020
14. Arbabian ME, Wagner MR (2020) The impact of 3D printing on manufacturer–retailer supply chains. *Eur J Oper Res* 285(2):538–552. <https://doi.org/10.1016/j.ejor.2020.01.063>
15. Çetinkaya C, Özceylan E (2018) Impacts of additive manufacturing on supply chain flow: a simulation approach in healthcare industry. *Logistics* 2(1):1. <https://doi.org/10.3390/logistics2010001>
16. Sun L, Wang Y, Hua G, Cheng T, Dong J (2020) Virgin or recycled? Optimal pricing of 3D printing platform and material suppliers in a closed-loop competitive circular supply chain. *Resour Conserv Recycl* 162:105035. <https://doi.org/10.1016/j.resconrec.2020.105035>
17. Weller C, Kleer R, Piller FT (2015) Economic implications of 3D printing: market structure models in light of additive manufacturing revisited. *Int J Prod Econ* 164:43–56. <https://doi.org/10.1016/j.ijpe.2015.02.020>
18. Petrovic V, Vicente Haro Gonzalez J, Jordá Ferrando O, Delgado Gordillo J, Ramón Blasco Puchades J, Portolés Griñan L (2011) Additive layered manufacturing: sectors of industrial application shown through case studies. *Int J Prod Res* 49(4):1061–1079. <https://doi.org/10.1080/00207540903479786>
19. Ben-Ner A, Siemsen E (2017) Decentralization and localization of production: the organizational and economic consequences of additive manufacturing (3D printing). *Calif Manage Rev* 59(2):5–23. <https://doi.org/10.1177/0008125617695284>
20. Chen Z (2017) The influence of 3D printing on global container multimodal transport system. *Complexity* 2017:7849670. <https://doi.org/10.1155/2017/7849670>
21. Woodson TS (2015) 3D printing for sustainable industrial transformation. *Development* 58(4):571–576. <https://doi.org/10.1057/s41301-016-0044-y>
22. Kellens K, Baumers M, Gutowski TG, Flanagan W, Lifset R, Duflou JR (2017) Environmental dimensions of additive manufacturing: mapping application domains and their environmental implications. *J Ind Ecol* 21(S1):S49–S68. <https://doi.org/10.1111/jiec.12629>
23. Franco D, Ganga GMD, de Santa-Eulalia LA, Godinho Filho M (2020) Consolidated and inconclusive effects of additive manufacturing adoption: a systematic literature review. *Comput Ind Eng* 148:106713. <https://doi.org/10.1016/j.cie.2020.106713>
24. Attaran M (2017) The rise of 3-D printing: the advantages of additive manufacturing over traditional manufacturing. *Bus Horiz* 60(5):677–688. <https://doi.org/10.1016/j.bushor.2017.05.011>
25. Durach CF, Kurpjuweit S, Wagner SM (2017) The impact of additive manufacturing on supply chains. *Int J Phys Distrib Logist Manag* 47(10):954–971. <https://doi.org/10.1108/IJPDLM-11-2016-0332>
26. Grand View Research (2021) Healthcare additive manufacturing market size, share & trends analysis report by technology (Laser Sintering, Stereolithography), by application (Medical Implants, Prosthetics), by material, and segment forecasts, 2019–2026. Market Analysis Report. <https://www.grandviewresearch.com/industry-analysis/healthcare-additive-manufacturing-market>. Accessed 1 January 2021
27. Javaid M, Haleem A (2019) Current status and applications of additive manufacturing in dentistry: a literature-based review. *J Oral Biol Craniofac Res* 9(3):179–185. <https://doi.org/10.1016/j.jobcr.2019.04.004>
28. Dawood A, Marti BM, Sauret-Jackson V, Darwood A (2015) 3D printing in dentistry. *Br Dent J* 219(11):521–529. <https://doi.org/10.1038/sj.bdj.2015.914>
29. Coachman C, Calamita MA, Coachman FG, Coachman RG, Sesma N (2017) Facially generated and cephalometric guided 3D digital design for complete mouth implant rehabilitation: a clinical report. *J Prosthet Dent* 117(5):577–586. <https://doi.org/10.1016/j.prosdent.2016.09.005>
30. Barone S, Neri P, Paoli A, Razonale AV (2018) Design and manufacturing of patient-specific orthodontic appliances by computer-aided engineering techniques. *Proc Inst Mech Eng* 232(1):54–66. <https://doi.org/10.1177/0954411917742945>
31. Yamamoto S, Kanazawa M, Iwaki M, Jokanovic A, Minakuchi S (2014) Effects of offset values for artificial teeth positions in CAD/CAM complete denture. *Comput Biol Med* 52:1–7. <https://doi.org/10.1016/j.combiomed.2014.05.011>
32. Chang S-L, Lo C-H, Jiang C-P, Juan D-J (2015) The fit consideration of the denture manufactured by 3D printing and sintering. *Int J Pharma Med Biol Sci* 4(3):184–187
33. Bae E-J, Jeong I-D, Kim W-C, Kim J-H (2017) A comparative study of additive and subtractive manufacturing for dental restorations. *J Prosthet Dent* 118(2):187–193. <https://doi.org/10.1016/j.prosdent.2016.11.004>
34. Achillas C, Aidonis D, Iakovou E, Thymianidis M, Tzetzis D (2015) A methodological framework for the inclusion of modern additive manufacturing into the production portfolio of a focused

- factory. *J Manuf Syst* 37:328–339. <https://doi.org/10.1016/j.jmsy.2014.07.014>
35. Sun L, Zhao L (2017) Envisioning the era of 3D printing: a conceptual model for the fashion industry. *Fash Text* 4(1):25. <https://doi.org/10.1186/s40691-017-0110-4>
36. Delic M, Evers DR (2020) The effect of additive manufacturing adoption on supply chain flexibility and performance: an empirical analysis from the automotive industry. *Int J Prod Econ* 228:107689. <https://doi.org/10.1016/j.ijpe.2020.107689>
37. Emelogu A, Marufuzzaman M, Thompson SM, Shamsaei N, Bian L (2016) Additive manufacturing of biomedical implants: a feasibility assessment via supply-chain cost analysis. *Addit Manuf* 11:97–113. <https://doi.org/10.1016/j.addma.2016.04.006>
38. Tang Y, Mak K, Zhao YF (2016) A framework to reduce product environmental impact through design optimization for additive manufacturing. *J Clean Prod* 137:1560–1572. <https://doi.org/10.1016/j.jclepro.2016.06.037>
39. Li Y, Jia G, Cheng Y, Hu Y (2017) Additive manufacturing technology in spare parts supply chain: a comparative study. *Int J Prod Res* 55(5):1498–1515. <https://doi.org/10.1080/00207543.2016.1231433>
40. Emelogu A, Chowdhury S, Marufuzzaman M, Bian L (2019) Distributed or centralized? A novel supply chain configuration of additively manufactured biomedical implants for southeastern US States. *CIRP J Manuf Sci Technol* 24:17–34. <https://doi.org/10.1016/j.cirpj.2018.12.001>
41. Strong D, Kay M, Conner B, Wakefield T, Manogharan G (2019) Hybrid manufacturing—locating AM hubs using a two-stage facility location approach. *Addit Manuf* 25:469–476. <https://doi.org/10.1016/j.addma.2018.11.027>
42. de Brito FM, Júnior GdC, Frazzon EM, Basto JP, Alcalá SG (2020) Design approach for additive manufacturing in spare part supply chains. *IEEE Trans Ind Inf* 17(2):757–765. <https://doi.org/10.1109/TII.2020.3029541>
43. Chergui A, Hadj-Hamou K, Vignat F (2018) Production scheduling and nesting in additive manufacturing. *Comput Ind Eng* 126:292–301. <https://doi.org/10.1016/j.cie.2018.09.048>
44. Yılmaz ÖF (2020) Examining additive manufacturing in supply chain context through an optimization model. *Comput Ind Eng* 142:106335. <https://doi.org/10.1016/j.cie.2020.106335>
45. Chung BD, Kim SI, Lee JS (2018) Dynamic supply chain design and operations plan for connected smart factories with additive manufacturing. *Appl Sci* 8(4):583. <https://doi.org/10.3390/app8040583>
46. Mashhadi F, Monroy SAS (2020) Deep learning for optimal resource allocation in IoT-enabled additive manufacturing. In: 2020 IEEE 6th World Forum on Internet of Things (WF-IoT), New Orleans, LA, USA, pp 1–6. <https://doi.org/10.1109/WF-IoT48130.2020.9221038>
47. Manero A, Smith P, Koontz A, Dombrowski M, Sparkman J, Courbin D, Chi A (2020) Leveraging 3D printing capacity in times of crisis: recommendations for COVID-19 distributed manufacturing for medical equipment rapid response. *Int J Environ Res Public Health* 17(13):4634. <https://doi.org/10.3390/ijerph17134634>
48. Tarfaoui M, Nachtane M, Goda I, Qureshi Y, Benyahia H (2020) 3D printing to support the shortage in personal protective equipment caused by COVID-19 pandemic. *Materials* 13(15):3339. <https://doi.org/10.3390/ma13153339>
49. Özceylan E, Çetinkaya C, Demirel N, Sabırlıoğlu O (2018) Impacts of additive manufacturing on supply chain flow: A simulation approach in healthcare industry. *Logistics* 2(1):1. <https://doi.org/10.3390/logistics2010001>

Publisher's note Springer Nature remains neutral with regard to jurisdictional claims in published maps and institutional affiliations.